

FILED  
OFFICE OF THE CITY CLERK  
OAKLAND

22 MAR 14 PM 4:05

APPROVED AS TO FORM AND LEGALITY

  
CITY ATTORNEY'S OFFICE

## OAKLAND CITY COUNCIL

RESOLUTION NO. 89085 C.M.S.

---

**A RESOLUTION GRANTING A CONDITIONAL AND REVOCABLE MAJOR ENCROACHMENT PERMIT TO CARBON SOLUTIONS TO ALLOW PORTIONS OF ELECTRIC VEHICLE CHARGING STATIONS AT COLISEUM GARDENS PARK ADJACENT TO 6818 LION WAY TO ENCROACH INTO THE PUBLIC RIGHT-OF-WAY ALONG LION WAY NEAR HAWLEY STREET AND ADOPTING APPROPRIATE CALIFORNIA ENVIRONMENTAL QUALITY ACT FINDINGS.**

**WHEREAS**, Carbon Solutions (Applicant), is an owner and operator of distributed energy assets including solar, battery and electric vehicle charging. They are also an aggregator and marketer of renewable energy certificates and carbon offsets. With funding provided from the Pacific Gas & Electric (PG&E) Electric Vehicle (EV) Fast Charge Program, Carbon Solutions plans to install EV charging stations at real property owned by the City Of Oakland and described in a Grant Deed Recorded by the Alameda County Clerk-Recorder and identified by the Alameda County Assessor as APN:41-4212-2 and commonly known as **Coliseum Gardens Park**, plans to file an application with the Oakland Department of Transportation for a Conditional and Revocable Encroachment Permit to allow portions of electric vehicle charging stations to encroach into the public right-of way on Lion Way near Hawley Street at Lafayette Square; and

**WHEREAS**, the renderings limits of the encroachments are delineated in Exhibit A; and

**WHEREAS**, the Applicant will apply for and secure a Major Encroachment permit with the Oakland Department of Transportation for a conditional and revocable major encroachment for vehicle charging equipment to encroach into the public right of way. The permit will require that the Applicant will prepare a complete Civil Engineering drawing for a permit (PX permit) for any required improvement needed to public facilities including curb, gutter, sidewalk, roadway, and accessible ramps and access points, and apply for and secure obstruction permit(s) and excavation permit(s) that may be needed for a complete installation of a fully functional vehicle charging station. Moreover, the applicant will apply for and secure utility permit from utility companies and building permits and electrical permits from the Building Department that may be needed for a fully functioning electrical charging station; and

**WHEREAS**, staff has determined, based on review of the preliminary plans and investigation of the site of the encroachments, said encroachments in the public right-of-way and their location will not interfere with public use of the roadway, sidewalk, buried utilities, and will not endanger the public welfare and convenience during said public use; and

**WHEREAS**, each as a separate and independent basis, this action is exempt from the California Environmental Quality Act (CEQA) pursuant to CEQA Guidelines sections 15301 (existing facilities), 15183 (projects consistent with General Plan and Zoning), and 15061(b)(3) (no significant effect on the environment); Section 15183 (projects consistent with a community plan, general plan, or zoning), Section 15301 (existing facilities), Section 15302 (replacement or reconstruction), and Section 15309 (inspections), each of which provides a separate and independent basis for CEQA clearance and when viewed collectively provide an overall basis for CEQA clearance; and

**WHEREAS**, a bond or securities in the amount no less than the full value of the work as verified by the City Engineer be submitted to the City and/or secured in a manner satisfactory to the City for the City to return the area to its original or better conditions should the Applicant fail to perform its obligation under the Major Encroachment permit to keep the installation free from graffiti and in good functioning conditions or to remove the improvements upon revocation of the Major Encroachment permit by the City Council. The bond shall be maintained for the life of the encroachment; now, therefore, be it

**RESOLVED:** That the City Council has reviewed all relevant documents relating to its grant of the encroachment permits that is the subject of this Resolution; and be it

**FURTHER RESOLVED:** That the Council finds that this project and action is exempt from the California Environmental Quality Act (CEQA) pursuant to the following CEQA Guidelines Sections: Section 15162 and 15163 (no further environmental review required); Section 15060(c)(2) (no direct or reasonably foreseeable indirect physical change in the environment); Section 15061(b)(3) (no significant effect on the environment); Section 15183 (projects consistent with a community plan, general plan, or zoning), Section 15301 (existing facilities), Section 15302 (replacement or reconstruction), and Section 15309 (inspections), each of which provides a separate and independent basis for CEQA clearance and when viewed collectively provide an overall basis for CEQA clearance; and be it

**FURTHER RESOLVED:** That the City Administrator or his designee shall file a Notice of Determination/Notice of Exemption with the Clerk of the County of Alameda for the project that is named in this resolution; and be it

**FURTHER RESOLVED:** That the City Council finds and determines that the decision made hereby is made in conformance with the requirements of CEQA; and be it

**FURTHER RESOLVED:** That upon the satisfactory completion of the required work and close-out of construction permits, and upon testing and acceptance of all equipment, and upon posting of the bond for the life of the asset by the Applicant and upon the approval of the Major Encroachment permit by the Oakland Department of Transportation Director, the "Applicant" will be then considered a "Permittee"; and be it

**FURTHER RESOLVED:** That said Major Encroachment permit is hereby conditioned by the following special requirements:

1. This agreement may be voided and the associated permits for encroachments may be revoked at any time and for reasons including but not limited to preservation of public safety or

failure on the part of the Permittee to maintain improvements, at the sole discretion of the City Council, expressed by resolution as being in the City's best interest, or the associated permit may be suspended at any time, at the sole discretion of the City Engineer, upon failure of the Permittee to comply fully and continuously with each and all of the conditions set forth herein and in the associated permits;

2. The Permittee hereby disclaims any right, title, or interest in or to any portion of the public right of way, including the sidewalk and street, and agrees that the encroachments are granted for an indeterminate period of time and that the use and occupancy by the Permittee of the public right of way is temporary and does not constitute an abandonment, whether expressed or implied, by the City of Oakland of any of its rights associated with the statutory and customary purpose and use of and operations in the public right-of-way;
3. The Permittee shall maintain fully in force and effect, at its own expense, at all times during the period for which the permit is in effect, good and sufficient public liability insurance and property damage insurance, both including contractual liability, insuring the City of Oakland, its officers, agents, employees, and volunteers against any and all claims arising out of the existence of the encroachments in the public right-of-way, as respects liabilities assumed under this permit, in amounts for each occurrence as determined and approved by the City's Risk Manager. The policy shall contain an endorsement declaring the policy as primary coverage on said liabilities. The Permittee shall submit a written certificate of such insurance or copy of the policy to City Engineer showing that insurance is in effect in compliance with this section, and shall file subsequent notices of the renewal thereof with the City Engineer. Such certificate shall state that the insurance coverage shall not be canceled, amended or be permitted to lapse without thirty (30) days prior written notice to City Engineer. The Permittee also agrees that the City Engineer, at his or her sole discretion, may review the type and amount of insurance required of the Permittee annually and may require the Permittee to increase the amount of and/or change the type of insurance coverage required, within reason and as circumstances warrant;
4. The Permittee shall be solely and fully liable and responsible for the repair, replacement, removal, reconstruction, and maintenance of any portion or all of the private improvements constructed or installed in the public right-of-way, whether by cause, neglect, or negligence of the Permittee or others, and for the associated costs and expenses necessary to restore or remove the encroachments to the satisfaction of the City Engineer, and shall not allow the encroachments to become a blight or a menace or a hazard to the health and safety of the general public;
5. The Permittee acknowledges and agrees that the encroachments are out of the ordinary and does not comply with City of Oakland standard installations. The Permittee further acknowledges and agrees that the City of Oakland and public utility agencies will periodically conduct work in the public right-of-way, including excavation, trenching, and relocation of its facilities, all of which may damage the encroachments. The Permittee further acknowledges and agrees that the City and public utility agencies take no responsibility for repair or replacement of the encroachments which may be damaged by the City or its contractors or public utility agencies or their contractors. The Permittee further acknowledges and agrees that upon notification by and to the satisfaction of the City Engineer, Permittee shall immediately repair, replace, or remove, at the sole expense of the Permittee, all damages to the encroachments that are directly or indirectly attributable to work by the City

or its contractors or public utility agencies or their contractors. Notwithstanding the foregoing, this section may be subject to mutually agreed upon limitations;

6. The Permittee shall remain liable for and shall immediately reimburse the City of Oakland for all costs, fee assessments, penalties, and accruing interest associated with the City's notification and subsequent abatement action for required maintenance, repairs, or removal, whether in whole or in part, of the encroachments or of damaged City infrastructure made necessary by the failure, whether direct or indirect, of the Permittee to monitor the encroachments effectively and accomplish preventative, remedial, or restorative work expeditiously. The City reserves the unqualified right to collect all monies unpaid through any combination of available statutory remedies, including recordation of Prospective Liens and Priority Liens/ Special Assessments with the Alameda County Recorder, inclusion of non-reimbursed amounts by the Alameda County Assessor with the annual assessment of the general levy, and awards of judgments by a court of competent jurisdiction;
7. Upon revocation of the encroachment permit, the Permittee shall immediately, completely, and permanently remove the encroachment from the public right-of-way, repair any damage resulting therefrom, and restore the public right-of-way to its original conditions existing before the construction or installation of the encroachment, to the satisfaction of the City Engineer and all at the sole expense of the Permittee;
8. This agreement and the associated permits for the encroachments shall become effective upon filing of this agreement with the Alameda County Recorder for recordation as an encumbrance of the property and its title;
9. The Permittee acknowledges that the City makes no representations or warranties as to the conditions beneath said encroachment. By accepting this revocable permit, Permittee agrees that it will use the encroachment areas at its own risk, is responsible for the proper coordination of its activities with all other permittees, underground utilities, contractors, or workmen operating, within the encroachment areas and for the safety of itself and any of its personnel in connection with its entry under this revocable permit;
10. The Permittee acknowledges that the City is unaware of the existence of any hazardous substances in either encroachment areas, and Permittee hereby waives and fully releases and forever discharges the City and its officers, directors, employees, agents, servants, representatives, assigns and successors from any and all claims, demands, liabilities, damages, actions, causes of action, penalties, fines, liens, judgments, costs, or expenses whatsoever (including, without limitation, attorneys' fees and costs), whether direct or indirect, known or unknown, foreseen or unforeseen, that may arise out of or in any way connected with the physical condition or required remediation of the excavation area or any law or regulation applicable thereto, including, without limitation, the Comprehensive Environmental Response, Compensation and Liability Act of 1980, as amended (42 U.S.C. Sections 9601 et seq.), the Resource Conservation and Recovery Act of 1976 (42 U.S.C. Section 466 et seq.), the Safe Drinking Water Act (14 U.S.C. Sections 1401, 1450), the Hazardous Waste Control Law (California Health and Safety Code Sections 25100 et seq.), the Porter-Cologne Water Quality Control Act (California Health and Safety Code Section 13000 et seq.), the Hazardous Substance Account Act (California Health and Safety Code Sections 253000 et seq.), and the Safe Drinking Water and Toxic Enforcement Act (California Health and Safety Code Section 25249.5 et seq.);

11. The Permittee further acknowledges that it understands and agrees that it hereby expressly waives all rights and benefits which it now has or in the future may have, under and by virtue of the terms of California Civil Code Section 1542, which reads as follows: "A GENERAL RELEASE DOES NOT EXTEND TO CLAIMS WHICH THE CREDITOR DOES NOT KNOW OR SUSPECT TO EXIST IN HIS OR HER FAVOR AT THE TIME OF EXECUTING THE RELEASE, WHICH IF KNOWN BY HIM MUST HAVE MATERIALLY AFFECTED HIS OR HER SETTLEMENT WITH THE DEBTOR." The permittee recognizes that by waiving the provisions of this section, Permittee will not be able to make any claims for damages that may exist, and to which, if known, would materially affect its decision to agree to these encroachments terms and conditions, regardless of whether Permittee's lack of knowledge is the result of ignorance, oversight, error, negligence, or any other cause;
12. The Permittee shall, and by the acceptance of these revocable permits agrees and promises:
  - a. to indemnify, defend, save and hold harmless the City of Oakland, its officers, agents, employees, and volunteers, to the maximum extent permitted by law, from any and all suits, claims, demands, liabilities, damages, actions, causes of action, penalties, fines, liens, judgments, costs, or expenses whatsoever (including, without limitation, attorneys' fees and costs) (collectively referred to as "claims"), whether direct or indirect, known or unknown, foreseen or unforeseen, brought by any person for or on account of any bodily injuries, disease or illness or damage to persons and/or property sustained or arising in the construction of the work performed under the permit or arising out of the Permittee's failure to perform the obligations with respect to the use and occupancy of the public right-of-way by virtue of the permit, to the extent that such claims were either (1) caused by the Permittee, its agents, employees, contractors or representatives, or (2) in the case of environmental contamination, the claim is a result of environmental contamination that emanates or emanated from the encroachment site, or was otherwise caused by the Permittee, its agents, employees, contractors or representatives; and
  - b. if any contamination is discovered below or in the immediate vicinity of the encroachments, and the contaminants found are of the type used, housed, stored, processed or sold on the properties, such shall amount to a rebuttable presumption that the contamination below, or in the immediate vicinity of, the encroachments were caused by the Permittee, its agents, employees, contractors or representatives; and
  - c. Permittee shall comply with all applicable federal, state, county and local laws, rules, and regulations governing the installation, maintenance, operation and abatement of the encroachments;
13. The encroachment permit and accompanying indenture agreements shall take effect when all the conditions hereinabove set forth shall have been complied with to the satisfaction of the City Engineer, and shall become null and void upon the failure of the Permittee to comply with all conditions;

- 14. The indenture agreement alone does not allow work to be done which requires permitting and/or inspection, and the Permittee shall obtain any and all required permits before beginning work;
- 15. The hereinabove conditions shall be binding upon the Permittee and the successive owners and assigns thereof; and be it

**FURTHER RESOLVED:** That the City Council, at its sole discretion and at a future date not yet determined, may impose additional and continuing fees as prescribed in the Master Fee Schedule, for use and occupancy of the public right-of-way; and be it

**FURTHER RESOLVED:** That this resolution shall take effect when all the conditions hereinabove set forth shall have been complied with to the satisfaction of the City Attorney and the City Engineer of the City of Oakland and shall become null and void upon the failure of the Permittee to comply with the conditions hereinabove set forth after notice and failure to cure such conditions in a reasonable manner; and be it

**FURTHER RESOLVED:** That the City Engineer is hereby directed to file a certified copy of this resolution for recordation with the Office of the Alameda County Clerk-Recorder as an encumbrance of the title of the property identified above without returning to Council.

IN COUNCIL, OAKLAND, CALIFORNIA,

MAR 15 2022

PASSED BY THE FOLLOWING VOTE:

AYES - FIFE, ~~WILLIAMS~~ KALB, KAPLAN, REID, TAYLOR, ~~WANG~~ AND PRESIDENT FORTUNATO BAS. — 6

NOES - 0

ABSENT - 0

ABSTENTION - 0

Excused - 2 Gallo & Thao

ATTEST:   
 ASHA REED  
 City Clerk and Clerk of the Council of the  
 City of Oakland, California

EXHIBIT A

PRELIMINARY DESIGN  
SCALE: 1" = 40'

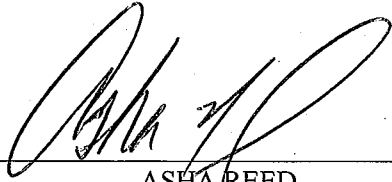

**BILL OF MATERIALS**

ITEM	UNIT	QUANTITY
TTM 300KVA, 80277V, PAD MOUNT TRANSFORMER WITH CONCRETE PAD	EACH	1
TTM 50' - 1 RISER POLE	EACH	1
TTM 40T FUSE	EACH	1
BTM 1 1/2" PVC CONDUIT	LF	770
TTM 6" PVC CONDUIT	LF	30
TTM 4" PVC CONDUIT	LF	85
BTM (2) 1/2 AWG THWN-2 CU + (1) 1/2 AWG THWN-2 CU EDC	LF	770
TTM 750AL GPR	LF	60
TTM 10 EPR	LF	480
TTM 18" WIDE OPEN CUT TRENCH - HARDSCAPE	LF	85
TTM 30" WIDE OPEN CUT TRENCH - SOFTSCAPE	LF	10
BTM 18" WIDE OPEN CUT TRENCH - HARDSCAPE	LF	85
BTM 18" WIDE OPEN CUT TRENCH - SOFTSCAPE	LF	40
TTM RESTORE ASPHALT PAVEMENT	SP	116
BTM RESTORE ASPHALT PAVEMENT	SP	85
BTM ADA GRADING (ASPHALT)	SP	470
BTM CONCRETE GRADING	SP	85
TTM RESTORE CONCRETE	SP	85
BTM RESTORE CONCRETE	SP	16
TTM RESTORE SOFTSCAPE	SP	10
BTM RESTORE SOFTSCAPE	SP	40
TTM RESTORE CONCRETE CURB	LF	2
BTM CONCRETE WHEEL STOP	EACH	6
BTM STRIPING	EACH	2
BTM SIGNAGE	EACH	1
BTM EV CHARGER FOUNDATION	EA	6

**SYMBOL LEGEND:**

	EXISTING BOLLARD
	EXISTING LIGHT POLE
	PROPOSED SIGN
	PROPOSED WHEELS STOP
	PROPOSED ELECTRIC VEHICLE SINGLE PORT PEDESTAL CHARGER
	805A PROPOSED METER SERVICE (COMBINATION)
	PROPOSED PG&E 300KVA PAD MOUNT TRANSFORMER
	EXISTING PG&E TRANSFORMER
	PROPOSED PG&E RISER POLE
	EXISTING UNDERGROUND LINE
	TTM UNDERGROUND CONDUIT LINE
	BTM UNDERGROUND CONDUIT LINE
	LIMITS OF WORK
	PROPOSED ADA STRIPE
	PROPOSED STRIPE
	PROPERTY LINE
	PROPOSED ASPHALT CONCRETE PAVEMENT
	PROPOSED CONCRETE
	PROPOSED TRUNCATED DOMES

- TTM NOTES:**
1. INSERT NEW POLE UPSTREAM OF 68TH AVE. INTERCEPT AN EXISTING 4" SPARE CONDUIT THAT RUNS THROUGH HAWLEY ST.
  2. EXTEND THE 4" SPARE TO THE PROPOSED PAD MOUNT TRANSFORMER.
  3. NEW TRANSFORMER TO BE LOCATED IN THE MOST FLAT SPOT OF THE GRASS TO AVOID THE EXISTING DRAINAGE SWALE.

- BTM NOTES:**
1. THE CITY OF OAKLAND HAS APPROVED OTHER PROJECTS THAT DO NOT SERVE A BUILDING AND TIE INTO PUBLIC ROW. THERE SHOULD BE NO ISSUE PERMITTING THE PROJECT.
  2. NEW METER PANEL TO BE LOCATED ADJACENT TO THE NEW TRANSFORMER ON THE MOST FLAT SPOT IN THE GRASS AVOIDING THE EXISTING DRAINAGE SWALE.
  3. TRENCHING SHOULD RUN IN THE ASPHALT TO AVOID DISTURBING THE EXISTING DRAINAGE SWALE AND WALK PATH.
  4. ADA STALLS WILL BE IN THE FURTHEST STALLS DUE TO A BETTER LOCATION FOR PUBLIC ROW TIE IN.
  5. ADA STALL CONFIGURATION CANNOT BE ANGLED DUE TO DRIVE ABLE WIDTH. ADDITIONAL STALLS WILL BE LOST FOR THE NEW CONFIGURATION.
  6. ALL STALLS ARE GREATER THEN 2% IN EACH DIRECTION AND WILL NEED TO BE REGRADED FOR ADA.
  7. EXISTING PUBLIC ROW AT THE SIDEWALK IS COMPLAINT. A SMALL SECTION WHERE THE ACCESS ABLE TIES INTO THE ROW WILL NEED REGRADED.

**STALL AND STATION COUNT**

IMPACTED EXISTING	QUANTITY
STANDARD STALLS	8
TOTAL	8
PROPOSED BY CHARGING	QUANTITY
VAN ACCESSIBLE STALLS	1
STANDARD ACCESSIBLE	1
STANDARD STALLS	4
TOTAL	6
BY CHARGING STATIONS	QUANTITY
DCFC (2x 8 KW) SINGLE PORT - PEDESTAL MOUNT	6
TOTAL	6

SCOPE OF WORK:  
PROJECT SCOPE INCLUDES (N) DC FAST CHARGERS. THE STALLS ARE LOCATED IN THE WEST SIDE OF LION WAY. THE EV STALLS WILL BE SERVICED BY PEDESTAL MOUNT DUSE. SEE DETAILED SITE LAYOUT FOR MORE INFORMATION.

EXHIBIT A



**Blair & Flynn**  
CONSULTANT  
Blair, Clark & Flynn  
Consulting Engineers  
401, Clay Avenue  
Suite 200  
Oakland, California 94612  
Tel: (415) 538-1100  
Fax: (415) 538-1300

DRAWN BY:	CYNTHIA MATA	SHEET NO. 1
CHECKED BY:	NATALIA PAVLENKO	
DATE:	02/18/2021	OF 2 SHEETS
SCALE AS NOTED		

### EXHIBIT A

PRELIMINARY DESIGN  
SCALE: 1" = 20'

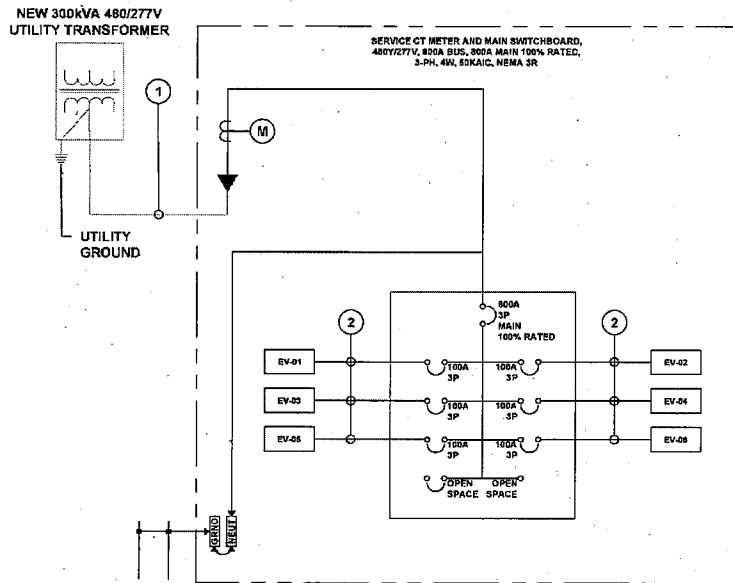

**NOTES:**

1. CONTRACTOR TO FIELD VERIFY MAIN FEED BREAKER SUPPORTING DISTRIBUTION PANEL IS APPROPRIATELY SIZED TO SUPPORT THE LOAD. CONTRACTOR SHALL CONTACT THE ENGINEERING TEAM IMMEDIATELY IF BREAKER IS FOUND TO BE INSUFFICIENT.
2. CONDUCTOR LENGTHS ARE ESTIMATES ONLY. LENGTHS ARE BASED ON DIAGRAMMATICAL MEASUREMENTS AND APPROXIMATED BURIED DEPTHS. THE EXACT ROUTING PATH, CONDUCTOR RUN LENGTHS AND INSTALLATION SHALL BE DETERMINED BY THE CONTRACTOR IN THE FIELD BASED ON EXISTING SITE CONDITIONS AND PHYSICAL MEASUREMENTS. CONTRACTOR TO ORDER CONDUCTOR BASED ON FIELD MEASUREMENTS.
3. CHARGING UNITS ARE EQUIPPED WITH AN INTEGRATED CONTACTOR TO PREVENT BACK FEEDING OF POWER TO THE SOURCE.
4. LOAD LIMITING FUNCTION OF CHARGERS SHALL BE CONFIGURED AS NEEDED SUCH THAT THE TOTAL LOAD OF ALL CHARGERS DOES NOT EXCEED PANEL RATINGS OR UTILITY TRANSFORMER CAPACITY.

**CIRCUIT NOTES**

NO	FROM	TO	CONFIGURATION
①	UTILITY TRANSFORMER	SERVICE CT METER AND MAIN SWITCHBOARD	SEE PG&E UTILITY DRAWINGS
②	SERVICE CT METER AND MAIN SWITCHBOARD	LEVEL 3 EV CHARGER	1-1/2" BELOW GRADE SCH40 PVC WITH (3) #3 AWG CU THWN-2, (1) #8 AWG CU THWN-2 GROUND CONDUCTOR

AC RUN MAXIMUM LENGTHS IS 400' INCLUDING BURIED DEPTH. ANY AC RUN LENGTHS BEYOND THIS MAXIMUM SHALL BE ADDRESSED WITH THE APPROPRIATE ENGINEERING TEAMS AS SOON AS THE SITUATION ARISES.

MAXIMUM AC VOLTAGE DROP (%)	1.1%
AVERAGE AC VOLTAGE DROP (%)	0.9%

EXHIBIT A



**Blair, Church & Flynn**  
CONSULTING ENGINEERS

CONSULTANT  
Blair, Church & Flynn  
Consulting Engineers  
455 Clark Avenue  
Suite 200  
Oakland, California 94612  
Tel: (415) 778-6800  
Fax: (415) 778-6800

DRAWN BY: CYNTHIA MATA  
CHECKED BY: NATALIA PAVLENKO  
DATE: 03/12/2021  
SCALE AS NOTED

SHEET NO. 3  
OF 3 SHEETS