

Wood Street Zoning District



Zoning Regulations, Standards, and Guidelines for
Development and Use of Property within the Wood
Street Zoning District

7 June, 2005
(Printed 15 June 2005)

TABLE OF CONTENTS

	Title Page	
	Table of Contents	i - iii
1.00	Overview	4
1.10	Overview of Wood Street Zoning District	
1.11	Application of the Wood Street Zoning District	
1.20	Components of Zoning Regulations	
	<i>Figure 1.20-1 'Vicinity Map'</i>	
	<i>Figure 1.20-2 'Zoning District - Aerial Photograph'</i>	
	<i>Figure 1.20-3 'District Boundary and Development Areas'</i>	
1.30	Conditions on Vesting Tentative Maps	
2.00	Area Designations and Definition of Terms	9
2.10	Area Designations	
2.20	Overlay Zones	
	<i>Figure 2.10-1 'Area Designations'</i>	
2.30	Definition of Terms	
3.00	Development Plans and Design Review	15
3.10	Preliminary Development Plan	
3.20	Review of Preliminary Development Plan	
3.30	Final Development Plan	
3.40	Review of Final Development Plan	
3.50	Design Review	
3.60	Modifications and Extensions	
3.70	Alterations after Issuance of Certificate of Occupancy	
4.00	Land Use Regulations	21
4.10	Land Use Regulations	
4.20	Activity Classifications	
4.21	Accessory Activities	
4.30	Joint Living and Working Quarters	
	<i>Table 4.10-1 'Activity Regulations'</i>	
5.00	Development Standards	28
5.10	Introduction to Development Standards	
	<i>Table 5.10-1 'Development Standards Summary'</i>	
5.20	Maximum Density	
5.21	Minimum Density	
5.22	Floor Area Ratio	
5.23	Maximum Height	
	<i>Figure 5.23-1 'Height Zones'</i>	
5.24	Minimum Setbacks	
	<i>Figure 5.24-1 'Minimum Street Setbacks'</i>	

5.30 Building Frontage
5.31 Building Frontage at Corner Locations on Wood Street
5.32 Street Front Entries
5.33 Street Front Openings
5.34 Projection over the Street Line or Street Setback Line
5.40 Usable Open Space for Residential Uses
5.41 Minimum Separation between Opposite Walls on the Same Lot
5.50 Required Off-Street Parking
Table 5.50-1 'Off-street Parking Requirements for Non-Residential Uses'
5.51 Dimensional Requirements for Off-Street Parking
5.52 Joint Use Parking
5.53 Curb Cuts
5.54 Off-Street Loading Requirements
5.60 Location and Screening of Surface Parking
5.61 Trees at Surface Parking Lots
5.62 Location and Screening of Tuck-under Parking
5.63 Location and Screening of Parking Garages
5.70 Limitations on Signs
5.80 16th Street Station and 16th Street Signal Tower
5.90 16th Street Plaza

6.00 Design Guidelines

61

6.10 Introduction to Design Guidelines
6.20 Architectural Character
6.21 Pedestrian Connections
6.22 Not Used
6.23 Building Massing
6.24 Building Articulation
6.25 Facades at Parking Garages
6.26 Balconies
6.27 Awnings and Canopies
6.30 Windows
6.31 Garage Doors
6.32 Service Access
6.33 Underground Utility Connections
6.34 Screening of Exterior Equipment
6.35 Mechanical Penetrations at Facades and Roofs
6.36 Waste Handling Areas
6.40 Exterior Materials
6.41 Exterior Color
6.42 Exterior Lighting
6.50 Signage and Graphics
6.60 Planting Areas

1.00

OVERVIEW

1.10 Overview of Wood Street Zoning District

The Wood Street Project is a proposed mixed-use redevelopment of the under-utilized industrial land around the vacant 16th Street Station in West Oakland. The goal of the Project is to create an active, pedestrian oriented urban community that addresses the demand for high quality residential units in the urban neighborhoods of downtown Oakland. The Project includes in aggregate up to 1,500 residential and live-work units, retail and office space, creation of publicly accessible open space, and rehabilitation and adaptive re-use of the historic 16th Street Train Station and Signal Tower.

The Wood Street Project consists of approximately 29.20 acres in total, and is generally bounded by 10th Street, Wood Street, West Grand Avenue and Frontage Road/I-880, as more particularly described in Figure 1.20-3. The various parcels of land that constitute the Wood Street project are collectively zoned as the Wood Street Zoning District.

The Wood Street Zoning District Regulations include Land Use Regulations, Development Standards and Design Guidelines. The purpose of these regulations is to ensure that the individual developments will be visually and functionally integrated, and that collectively the Project will be compatible with the existing neighborhood. For the purposes of appropriate regulation, the Wood Street Zoning District is divided into nine Development Areas, each subject to specific regulations. It is anticipated that each Development Area will be developed on an individual time line by the respective owner.

1.11 Application of Wood Street Zoning District

The zoning, standards, guidelines, regulations and other requirements for the development and use of property within the Wood Street Zoning District (Wood Street Zoning Regulations) shall be those set forth herein and where herein set forth shall supersede, without limitation, those set forth in Title 17 of the Oakland Municipal Code.

All applications for development and use of property within the Wood Street Zoning District, including, without limitation, Preliminary and Final Development Plans (as further described herein), shall be consistent with the provisions of Wood Street Zoning Regulations.

1.20 Components of Zoning Regulations

The primary components of the Wood Street Zoning Regulations are described below.

<i>Section No.</i>	<i>Title</i>
2.0	<i>Area Designations and Definition of Terms</i> Organization and Definitions describe the categorization of each area within the Wood Street Zoning District as either a Development Area, Public Access Area or Public Street and describe the elements of the Wood Street Zoning Regulations that govern each designated area.
3.0	<i>Development Plans and Design Review</i> This section describes the process for approval of applications for development and use of property within the Wood Street Zoning District.
4.0	<i>Land Use Regulations</i> The Land Use Regulations describe the allowable land uses and set forth land use regulations for each of the Development Areas within the Wood Street Zoning District.
5.0	<i>Development Standards</i> The Development Standards set forth mandatory requirements for all development and use of property within the Wood Street Zoning District.
6.0	<i>Design Guidelines</i> The Design Guidelines set forth design parameters for all development and use of property within the Wood Street Zoning District.

1.30 Conditions on Vesting Tentative Maps

Conditions On Subsequent Approvals Within the Wood Street Zoning District: Each of the conditions and each of the mitigation measures referenced in the Mitigation Monitoring and Reporting Program (attached as Exhibit B to the ordinance adopting this Wood Street Zoning District) shall be imposed upon the approval of any vesting tentative map within the Wood Street Zoning District. Each of the conditions imposed upon approval of any vesting tentative map within the Wood Street Zoning District shall be imposed as conditions of the Preliminary Development Plans for the parcels to which the conditions apply; and shall be imposed as conditions of the Final Development Plans if compliance with the conditions is required subsequent to the approval of the Final Development Plan.

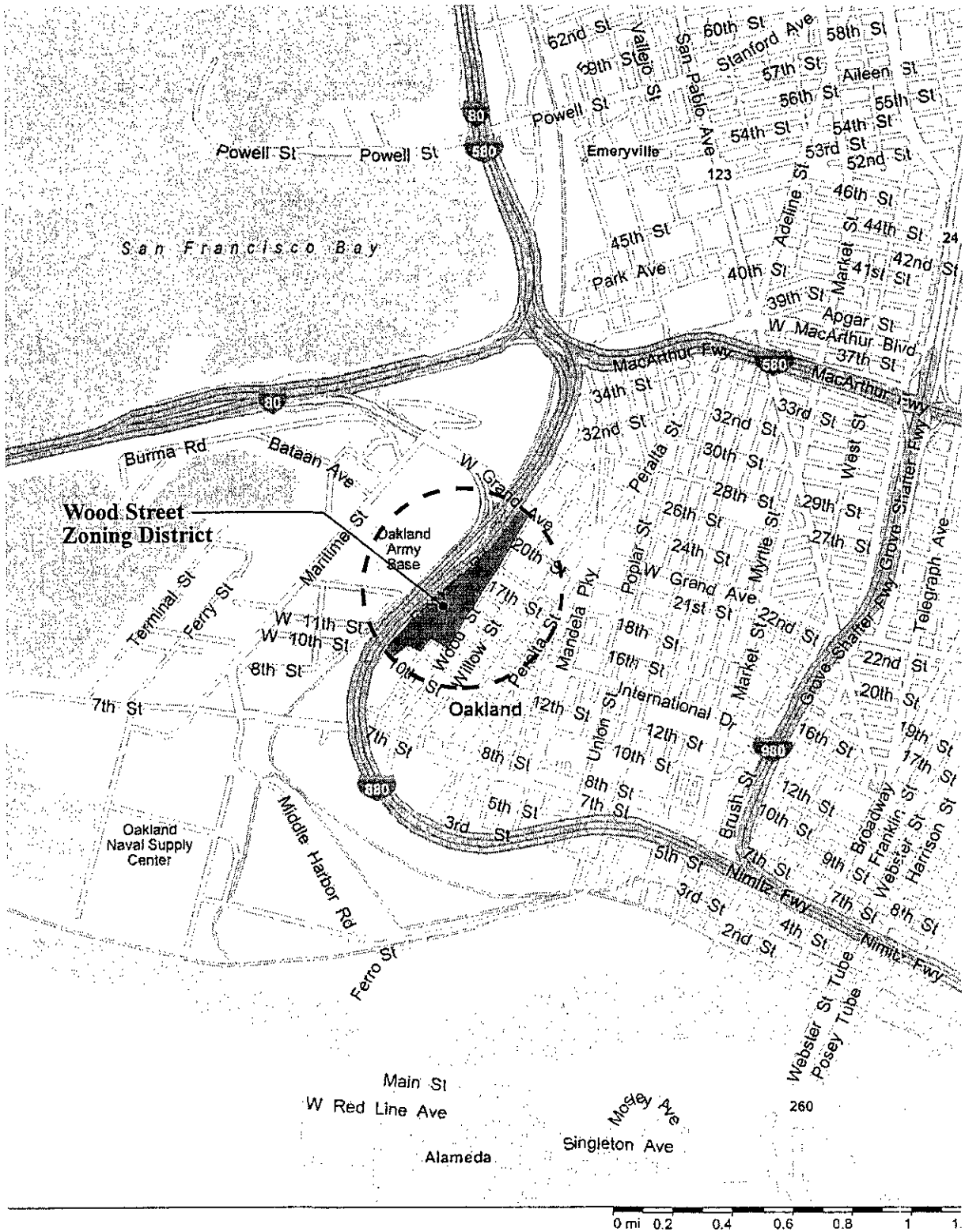

Vicinity Map

Figure 1.20-1

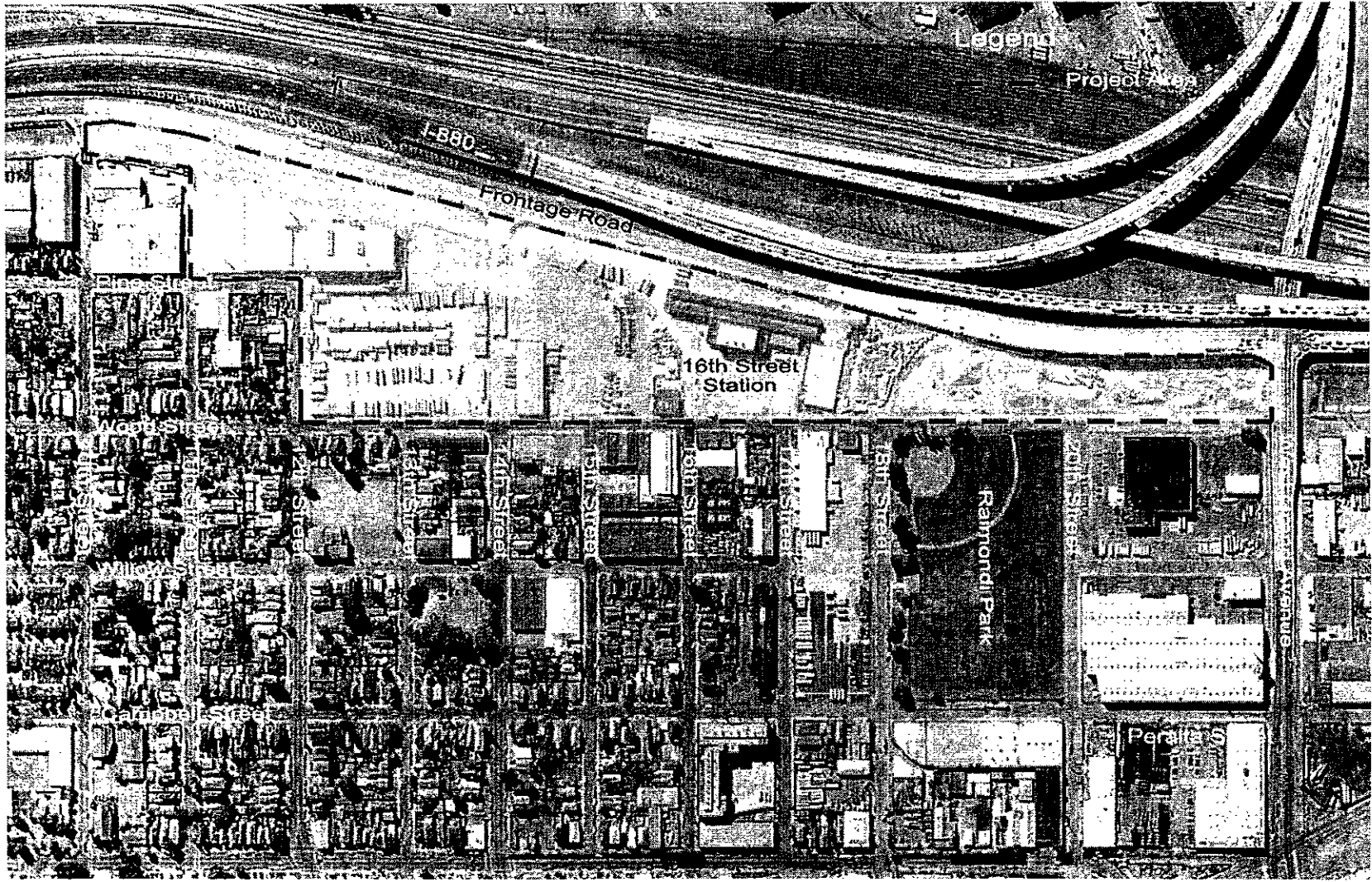

Overview

Zoning District - Aerial Photograph

Figure 1.20-2

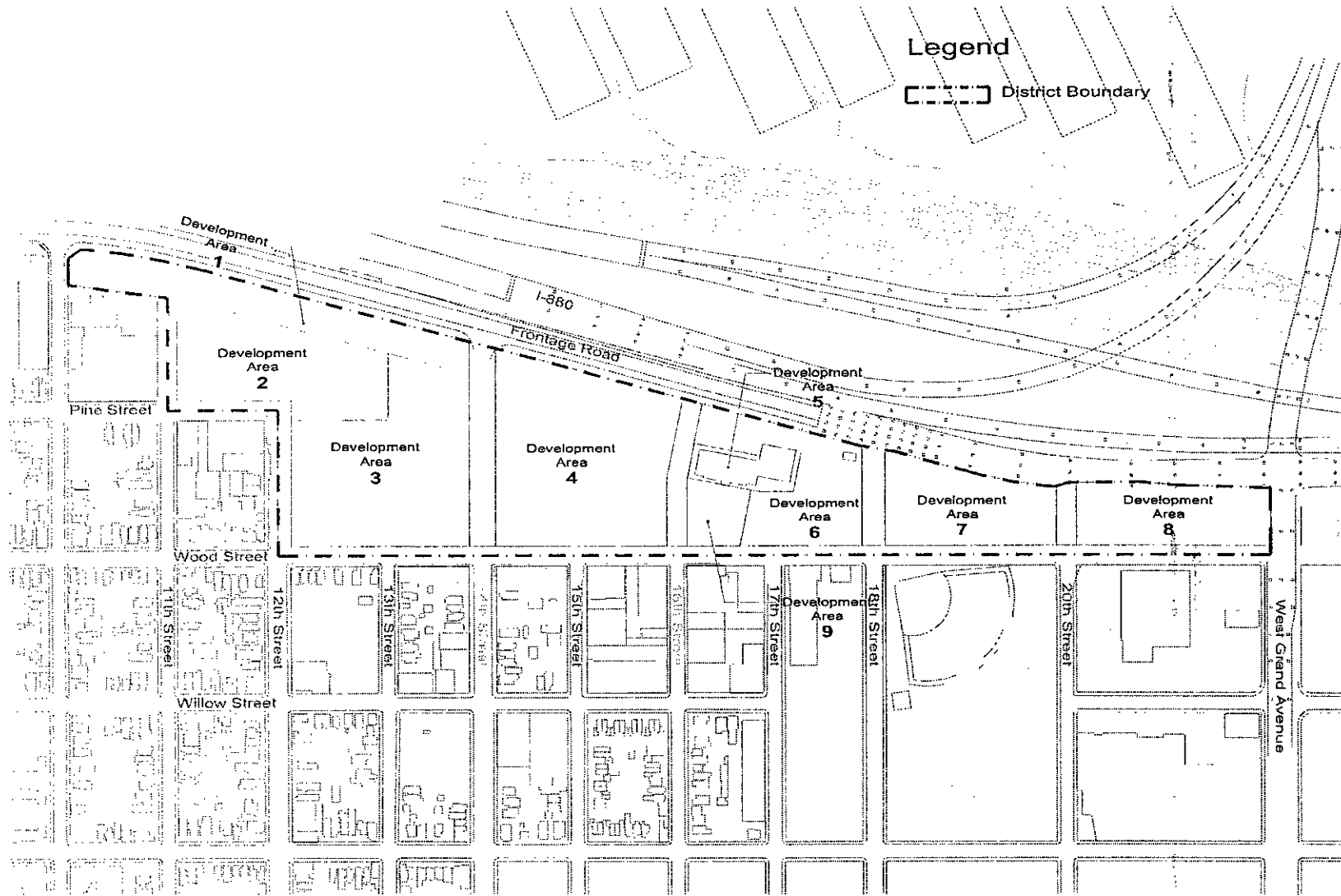

Overview

District Boundary and Development Areas

Figure 1.20-3

2.00

AREA DESIGNATIONS AND
DEFINITION OF TERMS

2.10 Area Designations

All land areas within the Wood Street Zoning District are designated as either Development Areas, Public Access Areas or Public Streets, as described below. *See Figure 2.10-1*

1. **Development Areas** are comprised of one or more privately owned lots that are intended for development. The Wood Street Zoning District includes nine Development Areas designated by the number one (1) through nine (9)
2. **Public Access Areas** are comprised of lots on which no permanent buildings are allowed. Public Access Areas include publicly accessible open space, parking areas, vehicular and pedestrian access areas, loading zones, and landscaped recreational spaces.

Public Access Areas include the extensions of 14th Street, 16th Street, 18th Street, and 20th Street. These areas provide pedestrian, bicycle, and emergency access only between Frontage Road and Wood Street. Vehicular through traffic from Wood Street to the Frontage Road is prohibited.

3. **Public Streets** are comprised of public rights-of-ways developed and maintained as public streets.

Refer to Chapter 17.09.040 for definition of "street".

2.20 Overlay Zones

Three Overlay Zones are established to provide for regulation of Development Areas in response to specific adjoining conditions, see Figure 2.10-1. Regulations applicable to Overlay Zones modify or replace the regulations otherwise applicable to the underlying Development Area as specified herein.

1. **Wood Street Overlay Zone** – The purpose of the Wood Street Overlay Zone is to establish a transition in scale between the Development Areas and the existing neighborhood, and to promote an active and pedestrian-scaled street frontage.

The Wood Street Overlay Zone is 30 feet in depth as measured from the street line at Wood Street, and parallels Wood Street between 12th Street and 20th Street.

2. **Plaza Overlay Zone** – The purpose of the Plaza Overlay Zone is to ensure that new development bordering the 16th Street Plaza creates a well-defined urban space with active ground floor uses facing the 16th Street Plaza, and to ensure that the scale of new buildings is complimentary to the scale of the 16th Street Train Station.

The Plaza Overlay Zone is twenty (20) feet in depth as measured from the Development Area Boundary. At Development Area 4 the Plaza Overlay Zone extends two hundred (200) feet from the street line at Wood Street. At Development Area 6 the Plaza Overlay Zone extends one hundred and fifty (150) feet from the street line at Wood Street, measured along the boundary of the Development Areas.

3. **Frontage Road Overlay Zone** – The purpose of the Frontage Road Overlay Zone is to allow greater flexibility for development fronting a major arterial street.

The Frontage Road Overlay Zone is twenty (20) feet in depth, as measured from the street line at Frontage Road, and extends from 10th Street north to the 16th Street.

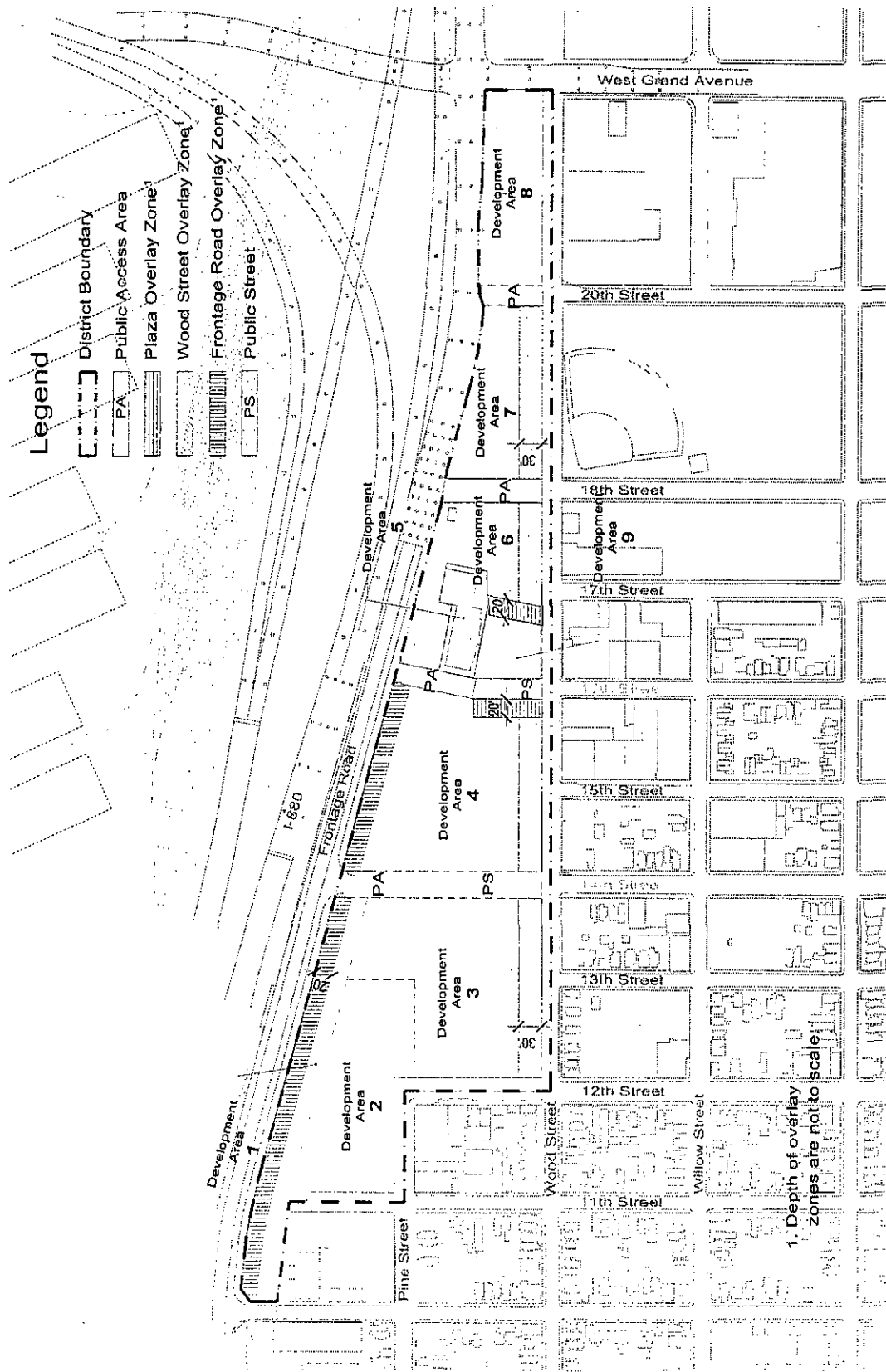

Area Designations

Figure 2.10-1

2.40 Definition of Terms

For the purpose of the Wood Street Zoning District Regulations the following definitions apply. For terms not defined below, the definition shall be as set forth in Section 17.09 of the Oakland Planning Code.

<i>At-grade</i>	Facilities or activities located on the ground with no structure or occupied space located below.
<i>Above grade</i>	Facilities or activities located over a parking garage or occupied space.
<i>Awning (or Canopy)</i>	A device that projects from the exterior facade of a building and is intended to shelter an opening or window below.
<i>Balcony</i>	A usable outdoor space located above the ground floor and projecting from the face of the building with no enclosed space immediately below.
<i>Bay Window</i>	An occupied space cantilevered from the face of the building and located above the ground floor.
<i>Below Grade Parking Garage</i>	A parking garage located below grade such that the first finished floor or outdoor area above the parking level is not more than five (5) feet above grade.
<i>Building Frontage</i>	Buildings or portions of buildings containing occupied space and located parallel and immediately adjacent to a street line or street setback line.
<i>Development Project</i>	Any facility constructed on a private parcel within a Development Area.
<i>Development Area</i>	See Section 2.10 of this Zoning District.
<i>Elevated Roadway</i>	Any roadway or portions of Frontage Road or West Grand Avenue more than five (5) feet above the average adjacent grade measured at the adjoining lot line.
<i>Equipment</i>	Utility meters, transformers, back flow preventers, check valves, heating, Satellite Dishes, ventilation and cooling equipment, and other devices associated with utility services or building systems. Equipment does not include plumbing and appliance vents, serving individual residential units, louvers, lighting and other minor devices.
<i>Facade</i>	The exterior wall of a building.
<i>Ground Floor</i>	The first story of a building located not more than five (5) feet above and not more than three (3) feet below the average finished grade at the adjoining street line or lot line. A ground floor may be located above a below grade parking garage.
<i>Ground Floor Parking Garage</i>	A parking garage located at the ground floor, as defined above.
<i>Interior Lot Line</i>	A lot line that separates private lots, not including lot lines adjoining Public Access Areas.
<i>Landscape Area</i>	Any portion of a Development Area that is not occupied by a building, parking area, service area or vehicular circulation area.

<i>Mixed-Use Development-</i>	An integrated development containing both residential and non-residential uses.
<i>Occupied Space</i>	A space within a building that contains activities associated with human occupation, excluding parking garages, storage areas, utility or service spaces and waste handling areas.
<i>Overlay Zone</i>	See Section 3.10 of this Zoning District.
<i>Parking Garage</i>	Any structure or portion of a structure containing parking stalls.
<i>Private Parking Garage</i>	Any parking garage serving an individual dwelling unit.
<i>Parallel</i>	A line shall be considered parallel to another line if the least angle created by their intersection (if any) is not more than 30 degrees.
<i>Perpendicular</i>	A line shall be considered perpendicular to another line if the least angle created by their intersection is not less than 60 degrees.
<i>Planning Code</i>	The City of Oakland Planning Code Title 17 of the Oakland Municipal Code, the most recent revision date as of the adoption of the Wood Street Zoning District.
<i>Public Access Area</i>	See Section 2.10 of this Zoning District.
<i>Public Streets</i>	See Section 2.10 of this Zoning District.
<i>Setback</i>	The distance from a lot line or street line to the face of a building or structure.
<i>Street Line</i>	A lot line dividing a lot from a public street, or a Public Access Area
<i>Street Frontage</i>	Any portion of a development project adjoining a street line
<i>Street Setback</i>	The required setback at a street line
<i>Street Setback Line</i>	The line established by the required setback from the street line
<i>Surface Parking</i>	Parking located at grade and not enclosed in a structure. Surface parking may have an overhead shelter.
<i>Tuck-under Parking</i>	Partially enclosed parking located below or partially below occupied space
<i>Visible from the street</i>	Visible from any point five (5) feet above the surface of a public street or Public Access Area immediately adjoining a lot or Development Area.

3.00

DEVELOPMENT PLANS AND
DESIGN REVIEW.

3.10 Preliminary Development Plan

The following provisions have been written to accommodate the unique challenges facing development within the Wood Street Zoning District, and comprise the exclusive regulations for Preliminary and Final Development Plans within that District.

Development of each Development Area within the Wood Street Zoning District requires submittal and approval of a Preliminary Development Plan and a Final Development Plan. More than one Development Area may be included in a Preliminary Development Plan. Both the Preliminary and Final Development Plans shall be prepared by a professional design team consisting of a registered civil engineer, or licensed architect, planner or licensed building designer, and other qualified professionals that the City may require. Other applications required for development and use of property within the Wood Street Zoning District (e.g., subdivision map) may be submitted before or concurrently with a Preliminary Development Plan.

The Preliminary Development Plan for one or more Development Areas shall include the following:

1. Streets, driveways, sidewalks, pedestrian and bike ways, and off-street parking and loading areas, including integration with surrounding uses;
2. Location and dimensions of structures;
3. Utilization of property for residential and non-residential use;
4. Estimated population;
5. Reservations for public uses, including schools, parks, playgrounds, and other open spaces;
6. Major landscaping features, including trees protected by O.M.C. Chapter 12.36, as it may be amended;
7. Creeks protected by O.M.C. Chapter 13.16, as it may be amended.
8. Historic resources pursuant to the City's Historic Preservation Element Policy 3.8 or as defined in Section 15064.5 of Title 22 of the California Code of Regulations;
and
9. Plan and elevation drawings establishing the scale, character, and relationship of buildings, streets, and open spaces, and a description of all exterior building materials.
10. A tabulation of the land use area and gross floor area to be devoted to various uses and a calculation of the average residential density per net acre and per net residential acre.
11. Preliminary Phasing Plan generally depicting projected development time frames including quantitative data, such as population, housing units, land use acreage, and other data sufficient to illustrate the relationship between the phasing of development and the provision of public facilities and services.
12. Preliminary public services and facilities plan including proposed location, extent and intensity of essential public facilities and services such as public and private streets and transit facilities, pedestrian access, bikeways, sanitary sewer service, water service, storm drainage structures, solid waste disposal and other utilities; and a table comparing the description to the existing location, extent, and intensity of such essential public facilities and services.
13. A public facilities financing plan.

3.20 Review of Preliminary Development Plan

The Planning Director shall forward the Preliminary Development Plan to the City Engineer for review no later than 10 days after a determination that the submittal is complete. The Planning Commission shall hold a public hearing on the Preliminary Development Plan no later than seventy-five days after it is sent to the City Engineer or within thirty days of the Planning Commission receiving a report from the City Engineer, whichever is earlier. Notice of the hearing shall be given by the City Clerk or Planning Director, as set forth in O.M.C. Section 17.140.030. The Planning Commission shall approve the Preliminary Development Plan if it makes written findings that the Preliminary Development Plan is in substantial conformance with the Wood Street Zoning Regulations. The Planning Commission shall disapprove the Preliminary Development Plan if it makes written findings that the Preliminary Development Plan is not in substantial conformance with the Wood Street Zoning Regulations and that it is not possible to require changes or impose conditions of approval as are reasonably necessary to ensure conformity to the Wood Street Zoning Regulations. The decision of the Planning Commission on the Preliminary Development Plan shall become final ten calendar days after the adoption of the findings, unless the Planning Commission decision is appealed to the City Council in accordance with O.M.C. Section 17.140.070. In the event the last date to file an appeal falls on a weekend or holiday when City offices are closed, the next date such offices are open for business shall be the last date of appeal.

If the Preliminary Development Plan for a Development Area satisfies the requirements for a Final Development Plan (as described in Section 3.30), the Preliminary Development Plan may also serve as a Final Development Plan, and the applicant shall not be required to file a separate Final Development Plan for that Development Area. In such case the development plan shall be entitled the Preliminary and Final Development Plan for the Development Area under consideration.

3.30 Final Development Plan

Unless an extension is granted pursuant to Section 3.40 below, a Final Development Plan for a Development Area or Public Access Area shall be submitted no later than one year after the final approval of the Preliminary Development Plan. The Final Development Plan shall include all information contained in the Preliminary Development Plan plus the following in sufficient detail to fully indicate the operation and appearance of all development shown on the Final Development Plan.

1. The location of all public infrastructure that provides water, sewage, and drainage facilities and other utility services;
2. The location of all private infrastructure that provides gas, electric, and other utility services;
3. Detailed building plans, elevations, sections, and a description of all exterior materials;
4. Landscape plans prepared by a landscape architect;
5. The character and location of signs;
6. Improvement plans for all public and private streets, driveways, sidewalks, pedestrian and bike ways, and off-street parking and loading areas;
7. Grading or other earth-moving plans; and
8. The public facilities financing plan approved as part of the Preliminary Development Plan modified as necessary to reflect changed conditions or new information.

If the Final Development Plan is not submitted within one year of the date of approval of the Preliminary Development Plan, the Preliminary Development Plan shall be void and of no further force and effect unless an extension is approved pursuant to Section 3.40 below.

An applicant shall submit all legal documents required for dedication or reservation of land and for all bonds or other forms of financial assurances acceptable to the City required for timely completion of public improvements necessitated by the project (including, without limitation, for guaranteeing 100% of the costs of completion and faithful performance of the work), with the Final Development Plan.

Construction pursuant to the Final Development Plan must commence no later than three years from the recordation of the final map for the Development Area to which the Final Development Plan applies.

3.40 Review of Final Development Plan

The Planning Director shall forward the Final Development Plan to the City Engineer for review no later than 10 days after a determination that the submittal is complete. The Planning Commission shall hold a public hearing on the Final Development Plan no later than seventy-five days after the Plan is sent to the City Engineer or within thirty days of the Planning Commission receiving a report from the City Engineer, whichever is earlier. Notice of the hearing shall be given by the City Clerk or Planning Director as set forth in O.M.C. Section 17.140.030

The Planning Commission shall approve the Final Development Plan if it makes written findings that the Final Development Plan is in substantial conformance with the Preliminary Development Plan and the Wood Street Zoning Regulations. The Planning Commission shall disapprove the Final Development Plan if it makes written findings that the Final Development Plan is not in substantial conformance with either the Preliminary Development Plan or the Wood Street Zoning Regulations and that it is not possible to require changes or impose conditions of approval as are reasonably necessary to ensure such conformity.

The decision of the Planning Commission on the Final Development Plan shall be final ten calendar days after the adoption of the findings unless the Planning Commission decision is appealed to the City Council in accordance with O.M.C. Section 17.140.070. In the event the last date to file an appeal falls on a weekend or holiday when City offices are closed, the next date such offices are open for business shall be the last date of appeal.

Approval of a Final Development Plan shall expire and be of no further force and effect if: (1) three years after the approval of the Final Development Plan substantial construction pursuant to a building permit has not commenced; or (2) construction has not continued in conformance with the approved phasing plan, as determined by the Planning Director and set forth in writing and provided to the applicant. The decision of the Planning Director may be appealed in writing to the Planning Commission within ten days of the date of the decision. The decision of the Planning Commission shall be final and not appealable.

3.50 Design Review of Preliminary or Final Development Plan

Design Review shall be required as part of the approval process for a Final Development Plan. After design review approval, no further design review approvals of the Development Area shown on the Final Development Plan shall be required except to the extent that the application for Final Design Review did not provide adequate information regarding one or more uses within the Development Area or Public Access Area to allow for Final Design Review. The procedure for Design Review shall follow the schedule outlined in Section 17.136.060. Design Review shall be limited to a determination of whether or not the proposed design is in substantial compliance with the design guidelines specified in these Wood Street Zoning Regulations.

3.60 Modifications and Extensions to a Preliminary or Final Development Plan

Minor changes to an approved Preliminary or Final Development Plan may be approved by the Director of City Planning prior to issuance of a certificate of occupancy if such changes are consistent with the purposes and character of the development plan. Proposed extensions to the one-year time limit, upon application filed at any time before said period has expired, shall be referred to the City Planning Commission, and the Commission may approve, modify, or deny such proposals. The decision of the Commission is appealable to the City Council.

3.70 Alterations after Issuance of Certificate of Occupancy

After issuance of certificate of occupancy within a Development Area, no building, Sign, or other facility shall be constructed or established, or altered in such a manner as to affect exterior appearance, unless plans for such proposal shall have been approved pursuant to the design review procedure in Chapter 17.136, as well as a finding that the proposal shall be in substantial compliance with the design guidelines specified in these Wood Street Zoning Regulations. However, design review approval is not required for temporary realty or development signs, holiday decorations, and displays behind a display window; and it is not required for mere changes of copy, including cutouts, on signs the customary use of which involves periodic changes of copy.

4.00

LAND USE REGULATIONS

4.10 Land Use Regulations

Applicability

The provisions of this section apply to all Development Areas within the Wood Street Zoning District.

Land Use Regulations

The following table lists the permitted, conditionally permitted, and prohibited activities in the Wood Street Zoning District. The descriptions of these activities are contained in Chapter 17.10.

- “P”. Designates permitted activities in the corresponding development area.
- “C”. Designates activities that are permitted only upon the granting of a conditional use permit in the corresponding zone.
- “L”. Designates activities subject to certain limitations listed at the bottom of the table.
- “--”. Designates uses that are prohibited in the corresponding development area.

4.20 Activity Classifications

Activity classifications are as set forth in Section 17.10 of the Planning Code.

4.21 Accessory Activities

Accessory activities shall be allowed as set forth in the Planning Code, Section 17.10.040.

4.30 Joint Living and Working Quarters

1. General Definitions.
 - a. Joint Living and Working Quarters: An integrated working space and residential space, either in single unit or multi-unit structure, that has been designed or structurally modified to accommodate joint residential occupancy and work activity and which:
 1. Is regularly used for such purpose by one or more persons residing in the unit;
 2. Includes complete kitchen space and sanitary facilities in compliance with the Building Code;
 3. Allows employees with associated required amenities as consistent with the building code; and
 4. Includes working space reserved and regularly used by one or more occupants of the unit.
 - b. "Category I Live/Work Unit." A unit specifically created to accommodate both residential and nonresidential activities but that emphasizes accommodating the residential activity. Any percentage of floor area in a Category I Live/Work Unit can be devoted to residential activities. A Category I Live/Work Unit is considered a residential facility.
 - c. "Category II Work/Live Unit." A unit specifically created to be used for both nonresidential and residential activities but that emphasizes accommodating the nonresidential activity. This type of unit only contains incidental residential accommodations, has no less than two-thirds of floor area devoted to work activities, and contains an active business. A Category II Live/Work is considered a nonresidential facility.
 - d. "Conversion." The rehabilitation of an existing nonresidential structure, including commercial and civic buildings, to a Live/Work or Work/Live facility, consistent with all other regulations for Category I and II.
2. General Provisions. Joint living and working quarters are permitted according to the following:
 - a. Category I Live/Work Units, including New Construction and Converted facilities, are permitted in all Development Areas.
 - b. Category II Work/Live Units, including New Construction and Converted facilities, are permitted in all Development Areas upon the granting of a conditional use permit pursuant to the conditional use permit procedure in Chapter 17.134 and subject to the Conditional Use Permit Criteria listed in Section 17.102.190E.
 - c. Permitted and Conditionally Permitted Activities. The permitted and conditionally permitted nonresidential activities in joint living and working quarters are restricted to those listed in the underlying Development Area except that permitted activities also include those allowed as Home Occupations described in Sections 17.112.030 and 17.112.040 of the Home Occupation regulations.

3. Use Permit Criteria. A conditional use permit required under Section 2b may be issued only upon determination that the proposal conforms to the general use permit criteria set forth in the conditional use permit procedure in Chapter 17.134 and to the following criteria:
 - a. Workers and residents will neither interfere with nor impair the purposes of the Wood Street Zoning District;
 - b. On site parking spaces for sites outside light industrial zones are screened from the street;
 - c. The site plan minimizes conflicts between pedestrians and vehicles;
 - d. The proposal will not impair the retention or creation of custom manufacturing or small scale light industrial facilities, where allowed in the Wood Street Zoning District;
 - e. The proposal is designed to minimize the impacts of nonresidential activities on residential activities in terms of noise, lights, glare, vibrations, dust, vapors, smoke, odors, electrical disturbance, or other factors;
 - f. The proposal incorporates sound attenuation and similar protective measures to protect residents from noise outside and within the development;
 - g. The location and design of the proposed development is adequately buffered, visually and spatially, from adjacent general industrial uses, if any, through appropriate on-site landscaping, screening and other buffering devices, and
 - h. Residents of the Project will not be exposed to toxic and/or hazardous materials that exceed local, state, and/or federal standards.

4. Development and Parking Standards for Joint Working Living Quarters
 - a. Development Standards for new construction will include all those listed in the underlying Development Area for Residential Activities and that apply to the Building Code occupancy type.
 - b. Off-street Parking for Live/Work Category I facilities and Live/Work Category II facilities shall be provided as set forth in Table 5.10-1.

TABLE 4.10-1

Land Use Classifications	Development Areas									Additional regulations
	1	2	3	4	5	6	7	8	9	
Residential Activities										
Permanent	P	P	P	P	--	P	P	P	--	
Residential Care occupying Single-Family Dwelling	C	C	C	C	--	C	C	C	--	17.102.212
Residential Care occupying Multi-Family Dwelling										17.102.212
Service-Enriched Permanent Housing	P(L1)	P(L1)	P(L1)	P(L1)	P(L1)	P(L1)	P(L1)	P(L1)	--	17.102.212
Transitional Housing	--	--	--	--	--	--	--	--	--	
Emergency Shelter	--	--	--	--	--	--	--	--	--	
Semi-Transient Residential	--	--	--	--	--	--	--	--	--	
Civic Activities										
Essential Services	--	P	--	P	P	P	--	P	--	
Limited Child-Care	--	P	--	P	P	P	--	P	--	
Community Assembly	--	P(L2)	--	P(L2)	C	P(L2)	--	P(L2)	--	
Community Education	C	C	C	C	C	C	C	C	C	
Non-Assembly Cultural	--	P	--	P	P	P	--	P	--	
Administrative	--	P(L3)	--	P(L3)	P	P(L3)	--	P	--	
Health Care	--	P(L3)	--	C	C	C	--	P	--	
Special health care	--	--	--	--	--	--	--	--	--	
Utility and Vehicular	--	P(L4)	--	P(L4)	P(L4)	P(L4)	--	P(L4)	--	
Extensive Impact	--	--	--	--	--	--	--	--	--	
Telecommunications	P	P	P	P	P	P	P	P	--	17.128
Commercial Activities										
General Food Sales	--	P(L5)	--	P(L5)	P(L5)	P(L5)	--	P(L5)	--	
Convenience Market	--	C(L6)	--	C(L6)	C(L6)	C(L6)	--	C(L6)	--	17.102.210
Fast-Food Restaurant	--	--	--	C	C	C	--	C	--	17.102.210
Alcoholic Beverage Sales	--	C(L7)	--	C(L7)	C(L7)	C(L7)	--	C(L7)	--	17.102.210
Convenience Sales and Service	--	P(L3)	--	P(L3)	P(L3)	P(L3)	--	P	--	
Mechanical or Electronic Games	--	--	--	--	--	--	--	--	--	
Medical Service	--	P(L8)	--	P(L8)	P(L8)	P(L8)	--	P(L8)	--	
General Retail Sales	--	P(L3)	--	P(L3)	P(L3)	P(L3)	--	P	--	
General Personal Service	--	P(L3)	--	P(L3)	P(L3)	P(L3)	--	P	--	
Consultative and Financial Service	--	P(L3)	--	P(L3)	P(L3)	P(L3)	--	P	--	
Consumer Laundry and Repair Service	--	--	--	--	--	--	--	--	--	
Group Assembly	--	--	--	--	C	--	--	P	--	
Administrative	--	P(L3)	--	P(L3)	P	P(L3)	--	P	--	
Business and Communication Services	--	C	--	C	C	C	--	P	--	
Retail Business Supply	--	P(L9)	--	P(L9)	P(L9)	P(L9)	--	P	--	

Land Use Regulations

TABLE 4.10-1

Land Use Classifications	Development Areas									Additional regulations
	1	2	3	4	5	6	7	8	9	
Research Service	--	--	--	--	--	--	--	P	--	
General Wholesale Sales	--	--	--	--	--	--	--	P	--	
Transient Habitation	--	--	--	--	--	--	--	P	--	
Construction Sales and Services	--	P(L10)	--	P(L10)	P(L10)	P(L10)	--	P(L10)	--	
Automotive Sales, Rental, and Delivery	--	--	--	--	--	--	--	--	--	
Automotive Servicing	--	--	--	--	--	--	--	--	--	
Automotive Repair and Cleaning	--	--	--	--	--	--	--	--	--	
Automotive Fee Parking	--	--	--	--	--	--	--	--	--	
Animal Care	--	--	--	--	--	--	--	--	--	
Undertaking Services	--	--	--	--	--	--	--	--	--	
Scrap Operation	--	--	--	--	--	--	--	--	--	
Manufacturing Activities										
Custom	--	P	--	C	C	C	--	P	--	
Light	--	C	--	--	--	--	--	C	--	
General	--	--	--	--	--	--	--	C	--	
Heavy	--	--	--	--	--	--	--	--	--	
Small Scale Transfer and Storage Hazardous Waste Management	--	--	--	--	--	--	--	--	--	
Industrial Transfer/Storage Hazardous Waste Management	--	--	--	--	--	--	--	--	--	
Residuals Repositories Hazardous Waste Management	--	--	--	--	--	--	--	--	--	
Agricultural and Extractive Activities	NO AGRICULTURAL AND EXTRACTIVE ACTIVITIES PERMITTED IN ANY ZONE									
Plant Nursery	--	--	--	--	--	--	--	--	--	
Crop and Animal Raising	--	--	--	--	--	--	--	--	--	
Mining and quarrying	--	--	--	--	--	--	--	--	--	
Off-street parking for prohibited activities										17.102.100A

Limitations:

- L1- Service Enriched Permanent Housing Residential activities for residents aged sixty (60) years or under requires the granting of a conditional use permit (see 17.134).
- L2- Only the following activities are permitted: 1) places of worship, churches, temples, mosques, and synagogues with a total floor area 3,000 square feet or less and 2) public, parochial, private non-profit clubs and lodges, meeting halls, recreation centers, gymnasiums 5,000 square feet or less
- L3- Activities with a total floor area greater than 3,000 square require the granting of a conditional use permit (see 17.134) and activities with a floor area over 5,000 square feet are prohibited.
- L4- Only police substations and neighborhood serving post offices that have a total floor area not exceeding 1,000 square feet are permitted. Other Utility and Vehicular Civic activities are prohibited.
- L5- Grocery markets shall 1) be limited to a maximum floor area of 3,000 square feet 2) only be open between 6:00 AM to 10:00 PM.
- L6- Convenience markets shall not be greater than 5,000 square feet.
- L7- Alcoholic Beverage Sales is limited to sale of beer and wine.
- L8- Floor area devoted to Medical Service Commercial activities limited to a maximum 2,500 square feet.
- L9- Retail Business supply stores are limited to office and art supply stores and shall be limited to a maximum 3,000 square feet.
- L10- Activities with a total floor area greater than 5,000 square require the granting of a conditional use permit (see 17.134) and activities with a floor area over 10,000 square feet are prohibited. This activity is limited to neighborhood serving construction product sales and services. (Note: Hardware Stores are a General Retail Commercial Activity, Refer to L3)

5.00

DEVELOPMENT STANDARDS

5.10 Introduction to Development Standards

Statement of intent

Each set of standards includes a statement of intent which sets forth the underlying purpose of that standard.

Applicability

The Development Standards are mandatory provisions that apply to all Development Areas in the Wood Street Zoning District, except as specified herein. Each section of the Development Standards includes a statement which indicates any limits of applicability within a particular Development Area and any conditions or locations that are exempt from the standards contained in that section.

Variances to Development Standards shall be considered in accordance with the provisions of Section 17.148 of the Planning Code, Variance Procedures.

General standards and standards applicable only to specific Development Areas

All sections include general standards that apply to all Development Areas. Certain sections also include standards only applicable to a specific Overlay Zone or Development Area. In the case of conflict, standards applicable to a specific Overlay Zone or Development Area shall take precedence over general standards.

Summary of Development Standards

Key Development Standards are summarized in Table 5-10-1 Summary of Development Standards. Refer to individual sections for full description of standards.

Table 5.10-1 Development Standards Summary									
Standard	Development Area 1	Development Area 2	Development Area 3	Development Area 4	Development Area [6] 5	Development Area 6	Development Area 7	Development Area 8	Development Area [7] 9
Maximum Residential Density [1]									
1-Min. land area per dwelling unit	1535.22 sf	848.85 sf	1217.50 sf	613.75 sf	NA	549.06 sf	679.02 sf	331.65 sf	NA
2-Max. dwelling units per acre	28.4 DU/A	51.5 DU/A	35.8 DU/A	71.1 DU/A	NA	79.33 DU/A	64.2 DU/A	131.3 DU/A	NA
3-Max. number of units	82	189	200	450	0	215	170	264	NA
Minimum Density for Residential Uses	1 unit per 2,000sf of site area (22 DU/A)	1 unit per 2,000sf of site area (22 DU/A)	1 unit per 2,000sf of site area (22 DU/A)	1 unit per 1,000sf of site area (44 DU/A)	NA	1 unit per 1,000sf of site area (44 DU/A)	1 unit per 1,000sf of site area (44 DU/A)	1 unit per 1,000sf of site area (44 DU/A)	NA
Maximum FAR (For non-residential uses)	NA	1.38 : 1	NA	2.02 : 1	0.622:1	2.02 : 1	NA	2.947 : 1	NA
Max. Area of Non-Residential Uses	0	220,779sf	0	40,000sf	23,000sf	6,000sf	0	258,000sf	NA
Maximum Height	65 ft [2]	65 ft [2]	50 ft [2][4]	65 ft [2]	[3]	65 ft [2]	90 ft [2]	90 ft [4]	NA
Minimum Street Setbacks [5]									
- Wood Street	10 ft	10 ft	10 ft	10 ft	10 ft	10 ft	10 ft	10 ft	NA
- 12th Street	0 ft	0 ft	0 ft	0 ft	0 ft	0 ft	0 ft	0 ft	NA
- Frontage Road	0 ft	0 ft	0 ft	0 ft	0 ft	0 ft	0 ft	0 ft	NA
- 14th Street	0 ft	0 ft	0 ft	0 ft	0 ft	0 ft	0 ft	0 ft	NA
- Public Access Areas	0 ft	0 ft	0 ft	0 ft	0 ft	0 ft	0 ft	0 ft	NA
Minimum Interior Setbacks	5 ft	5 ft	10 ft	5 ft	5 ft	5 ft	0 ft	0 ft	NA
Minimum Usable Open Space (per dwelling unit, DU)									
- Minimum area per unit	100 sq ft	75 sq ft	100 sq ft	75 sq ft	NA	75 sq ft	75 sq ft	50 sq ft	NA
Required Off-Street Parking for Residential Uses	1.1 space per D.U.	1.1 space per D.U.	1.1 space per D.U.	1.1 space per D.U.	1.1 space per D.U.	1.1 space per D.U.	1.1 space per D.U.	1.1 space per D.U.	NA
Required Off-Street Parking for Joint Living & Working Quarters	1.2 space per L/W.U.	1.2 space per L/W.U.	1.2 space per L/W.U.	1.2 space per L/W.U.	1.2 space per L/W.U.	1.2 space per L/W.U.	1.2 space per L/W.U.	1.2 space per L/W.U.	NA
Required Off-Street Parking for Non-Residential Uses	See Table 5.50-1	See Table 5.50-1	See Table 5.50-1	See Table 5.50-1	See Table 5.50-1	See Table 5.50-1	See Table 5.50-1	See Table 5.50-1	See Table 5.50-1

1. Density based on regular dwelling units.
2. Reference Section 5.23 and Figure 5.23-1 for height restrictions in Overlay Areas.
3. See Section 5.80 for restrictions on additions to 16th Street Train Station.
4. Reference Section 5.23 for additional height restrictions.
5. Reference Minimum Street Setbacks, Figure 5.24-1
6. Reference Section 5.80 for Standards applicable to Development Area 5.
7. Reference Section 5.90 for Standards applicable to Development Area 9.

Development Standards Summary

Table 5.10-1

5.20 Maximum Density

Statement of Intent

The intent of the maximum density standard is to establish a limit on the number of dwelling units allowed in a specific Development Area. Maximum density is regulated by means of a required minimum land area per regular dwelling unit.

Applicability

The following standards apply to all residential uses.

General Standards

1. The maximum allowable density for residential development in each Development Area shall be as set forth in *Table 5.10-1 Development Standards Summary*.
2. For efficiency dwelling units, the minimum allowable lot area per unit shall be the same as for regular dwelling units.
3. One additional unit is allowed if after division of the total lot area by the minimum lot area the remainder is equal to $2/3$ or greater of the minimum lot area.
4. Refer to the Planning Code for Definition of Regular Dwelling Unit and Efficiency Dwelling Unit.

5.21 Minimum Density

Statement of Intent

The intent of the minimum density standard is to ensure that residential development in the Wood Street Zoning District provides a number of dwelling units sufficient to create an active, mixed use, urban development. Minimum density is regulated by means of a maximum allowable lot area per regular dwelling unit.

Applicability

The following standards apply to all residential uses.

General Standard

1. The minimum allowable density for residential development in each Development Area shall be as set forth in *Table 5.10-1 Development Standards Summary*.
2. For rooming units, there is no minimum density standard.

5.22 Floor Area Ratio

Statement of Intent

The intent of the floor area ratio standard is to establish a maximum allowable floor area for non-residential uses on a given lot.

Applicability

The following standard applies to all non-residential uses except as specified below.

Exceptions

The locations or conditions indicated below are exempt from the standards set forth in this section:

1. Non-residential uses located in existing buildings

General Standard

1. The allowable FAR for each Development Area shall be as set forth in *Table 5.10-1 Development Standards Summary*.
2. On lots containing both residential and non-residential uses, no portion of the lot area used to meet the minimum lot area per dwelling unit set forth in the density standard shall be used as a base for computing the allowable floor area for any non-residential facility on the same lot.

5.23 Maximum Height

Statement of Intent

The intent of the maximum height standard is to establish a maximum allowable height of buildings to ensure a compatible relationship with surrounding development.

Applicability

The following standards apply to all facilities.

General Standards

1. The maximum height allowed in each Development Area shall be as set forth in *Table 5.10-1 Development Standards Summary*, except as noted otherwise below. See height zones, *Figure 5.23-1* for graphic illustration of maximum height.
2. Projections above height limits are allowed as set forth in Section 17.108.30 of the Planning Code.

Standards for Development Area 3

3. A maximum height of sixty five (65) feet shall apply to any portion of a structure located within that portion of Development Area 3 indicated in *Figure 5.23-1*.
4. A maximum height of forty (40) feet shall apply to any portion of a structure located within twenty (20) feet of the street line on 12th Street.

Standards for Development Area 6

5. A maximum height of thirty five (35) feet shall apply to any portion of a new structure located on that portion of Development Area 6 located between the 16th Street Station/ Development Area 5 and the Frontage Road.

Standards for Development Area 8

6. A maximum height of fifty (50) feet shall apply to any portion of a structure located within fifteen (15) feet of the street setback line at Wood Street.

5.24 Minimum Setbacks

Statement of Intent

The intent of the minimum setbacks standard is to establish a minimum required distance between the building face and the property line.

Applicability

The following standards apply to all uses.

Exceptions

The locations or conditions indicated below are exempt from the standards set forth in this section:

1. Existing buildings

Setback Classifications

For the purposes of the Wood Street Zoning District Regulations, the typical classifications of front, side, and rear yards are replaced by the setback classifications described below.

1. **Street setbacks** refer to required setbacks from street lines adjoining Public Streets or Public Access Areas.
2. **Interior setbacks** refer to required setbacks at all lot lines separating privately owned lots within a Development Area.

General Standards

1. Minimum required setbacks shall be as set forth in *Table 5.10-1, Development Standards Summary*. See Figure 5.24-1 for graphic illustration of minimum street setbacks.
2. The required setback area shall be unobstructed except for facilities allowed by Section 17.108.130 of the Planning Code.

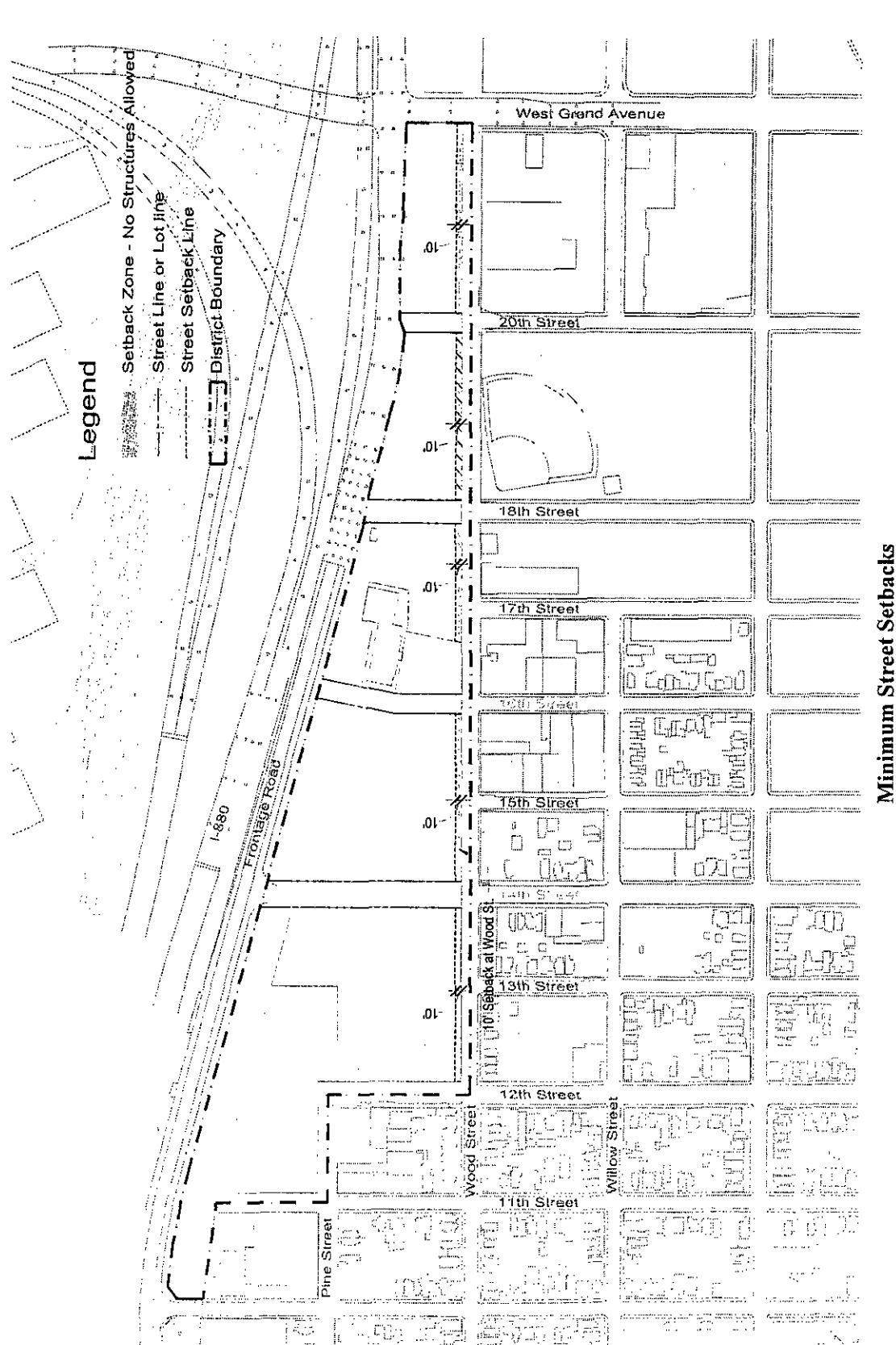

Minimum Street Setbacks

Figure 5.24-1

5.30 Building Frontage

Statement of Intent

The intent of building frontage standards is to ensure that building frontage containing occupied space is provided at the street line (or street setback line) to create an active, well defined street.

Applicability

The following standards apply to all uses except as specified below.

Exceptions

The locations or conditions indicated below are exempt from the standards set forth in this section:

1. Existing buildings
2. Development located adjacent to elevated roadways
3. Development located in the Frontage Road Overlay Zone

General Standards

1. For each lot, a minimum percentage of each street line or street setback line shall be occupied by building frontage as indicated below. See *Figure 5.30-1*.

a. Wood Street Overlay Zone	75%
b. Plaza Overlay Zone	90%
c. All other locations	50%
2. The required building frontage, shall be located within five feet of the street line or street setback line.
3. Required building frontage shall be at least one story or fifteen (15) feet in height, at least twenty (20) feet in depth and shall contain occupied space at the ground floor.
4. Covered arcades, porches, gate houses and similar architectural elements that create sheltered outdoor space may be considered building frontage, provided these elements adjoin or provide access to occupied space.

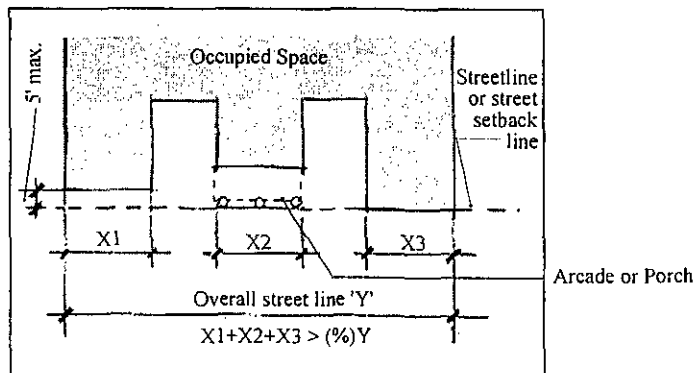

Figure 5.30-1

Standards for Development Area 8

1. A minimum of 50% of the required building frontage at Wood Street shall contain occupied space. The remainder of the required building frontage may contain parking or other non-occupied uses.

Standards for the Plaza Overlay Zone

1. At ground level, buildings within the Plaza Overlay Zone shall contain occupied space accommodating one of the following:
 - a. Civic or commercial uses accessible to the public during business hours.
 - b. Lobbies serving occupied space above
2. Upper floors within the Plaza Overlay Zone shall contain occupied space.
See *Figure 5.30-7*

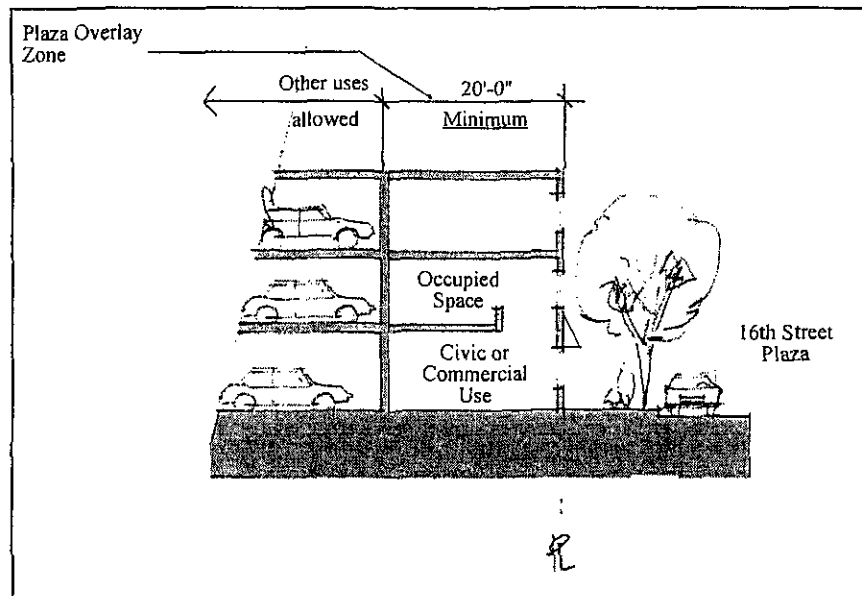

Building frontage at Plaza Overlay Zone

Figure 5.30-3

5.31 Building Frontage at Corner Locations on Wood Street

Statement of Intent

The intent of the standards contained in this section is to ensure that occupied building frontage is provided at corner locations to define and activate the street frontage.

Applicability

The following standards apply to all uses located on Wood Street at intersections with public streets or with Public Access Areas:

Exceptions

The locations and conditions indicated below are exempt from the standards set forth in this section:

1. The intersection of Wood Street and West Grand Avenue, (West Grand Avenue is elevated at this location)

General Standards

1. At corner locations on Wood Street a continuous building frontage shall be provided at the street setback line for a distance of thirty (30) feet minimum along Wood Street, and twenty (20) feet minimum along the intersecting street line. See *Figure 5.31-1*
2. Required building frontage at corner locations shall be at least one story or fifteen (15) feet in height, at least twenty (20) feet in depth and shall contain occupied space at the ground floor.
3. Recessed or beveled corner entries are acceptable at corner frontages.
4. A minimum of one pedestrian entry into the building is required to be provided from either Wood Street or the intersecting street (or Public Access Area). Required entry shall be within thirty (30) feet of the corner, as measured from the intersection of the street line at Wood Street and the street line at the intersecting street.

Standards for Plaza Overlay Zone

5. Corner setbacks are allowed to provide outdoor seating areas for cafes, restaurants or similar General Food Sale activities.

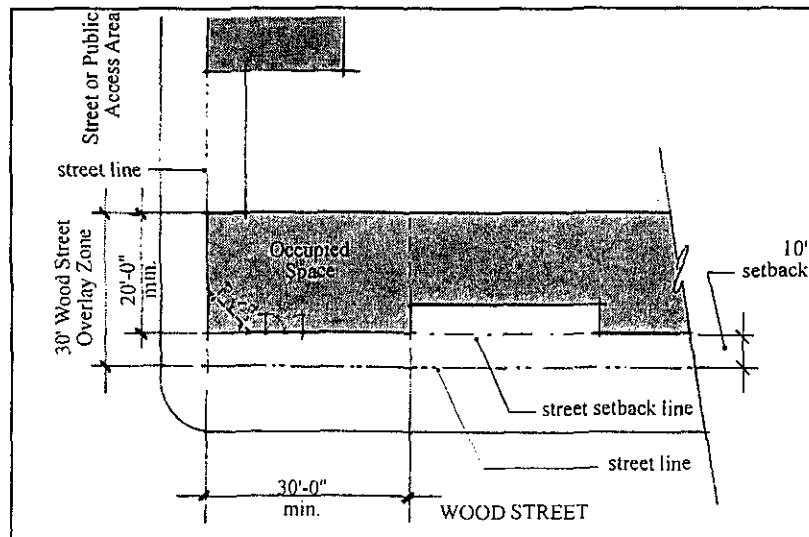

Figure 5.31-1

5.32 Street Front Entries

Statement of Intent

The intent of the street front entries standard is to ensure a consistent pattern of street oriented pedestrian entries.

Applicability

The following standards shall apply to all uses located within the Wood Street and Plaza Overlay Zones, and all uses adjacent to the street line at Public Access Areas.

Exceptions

The locations and conditions indicated below are exempt from the standards set forth in this section:

1. Building frontage located in Development Area 8
2. Building frontage located in the Frontage Road Overlay Zone
3. Building frontage adjacent to elevated roadways
4. Existing buildings

General Standards

1. For each lot, the average distance and the maximum distance between pedestrian entries at the street line or street setback line shall not exceed the distances set forth below. The distance between entries shall be measured from center line of entry to center line of entry.

	Maximum Distance Between Adjacent Entries
Wood Street Overlay	60'
Plaza Overlay Area	60'
All Other Street Frontages	100'

2. For the purpose of this standard, pedestrian entries include the following:
 - a. Entry to individual units or commercial spaces
 - b. Common entry to a building containing more than one unit
 - c. Outdoor entry leading to common outdoor space
3. The followings are not considered entries for the purpose of this standard:
 - a. Emergency exits
 - b. Access to service or utility enclosures

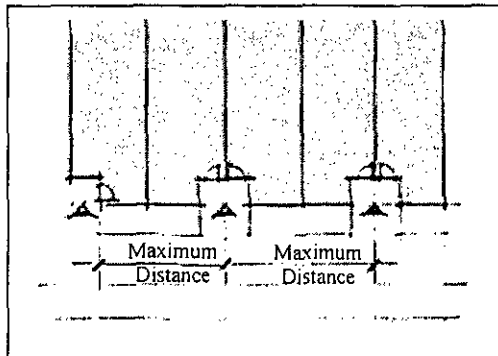

Figure 5.23-1

4. Required entries must be visible from and located within twenty (20) feet of the street line or street setback line.
5. Entry access shall be direct from the public right-of-way by means of walks, stairs, ramps, gates, or combination thereof.
6. All required pedestrian entries shall be marked by either an overhang, awning, building articulation, and/or architectural feature
7. All entries shall incorporate exterior lighting at the point of entry

5.33 Street Front Openings

Statement of Intent

The intent of the street front openings standard is to encourage street oriented development.

Applicability

The following standards apply at all ground floor building frontage located within the Wood Street Overlay Zone.

General Standards

1. Ground level openings in the form of a door, window, or passage way shall be located no more than twenty-five (25) feet apart measured parallel to the street line. (See Figure 5.33-1)
2. A minimum of 25% of the ground floor wall area shall consist of transparent openings, pedestrian entries, or a combination of the two. See *Figure 5.33-1*
 - a. The ground floor wall area shall be measured from the first floor above grade to the floor level above, or to a point twelve (12) feet above the first floor, whichever is less.
 - b. Service area and utility doors, emergency exists, and ventilation grills are not considered openings for the purposes of this standard.
 - c. The vertical distance between the window sill of a required opening and the adjacent sidewalk shall not exceed 4'-6".
 - d. In the case where occupied space is located over a below grade garage, The vertical distance between the window sill of required opening and the first floor level shall not exceed 3'-0".

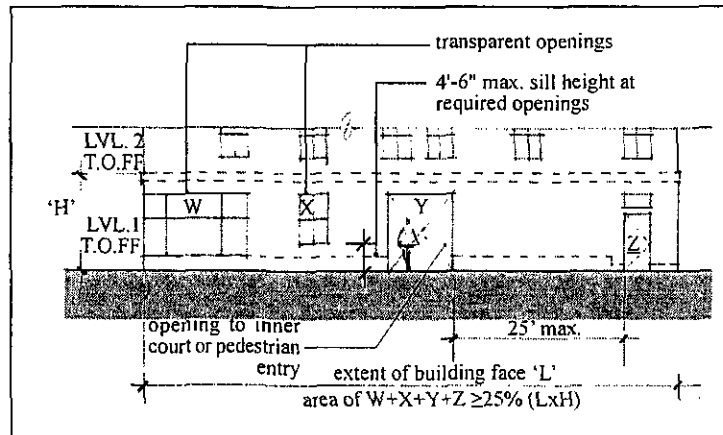

Figure 5.33-1

5.34 Projections over the Street Line or Street Setback Line

Statement of Intent

Bay windows at street frontages provide articulation to the building form and improve security by allowing residents to overlook the street. Bay windows are allowed to project over the street line subject to the standards set forth in this section.

Applicability

The following standards apply to all uses.

General Standards

1. Bay windows projecting over the street line or street setback line must meet the following criteria:
 - a. Bays must be self supporting and the bottom of the bay window must be no less than nine (9) feet above the height of the adjoining sidewalk
 - b. Overall width of a single bay shall not exceed fourteen (14) feet
 - c. The horizontal distance between bays shall be a minimum of three (3) feet
 - d. Bays greater than eighteen (18) inches in depth must have windows on at least two separate wall planes.
2. The maximum allowable horizontal projection over the street line or street setback line is three (3) feet.
3. Within any one-hundred foot length of street frontage, the overall width of bays projecting over the street line or street setback line shall not exceed sixty percent (60%) of the corresponding horizontal wall dimension.
4. These standards supersede the provisions of Section 17.108.130 of the Planning Code related to projections of bays into required front yards.

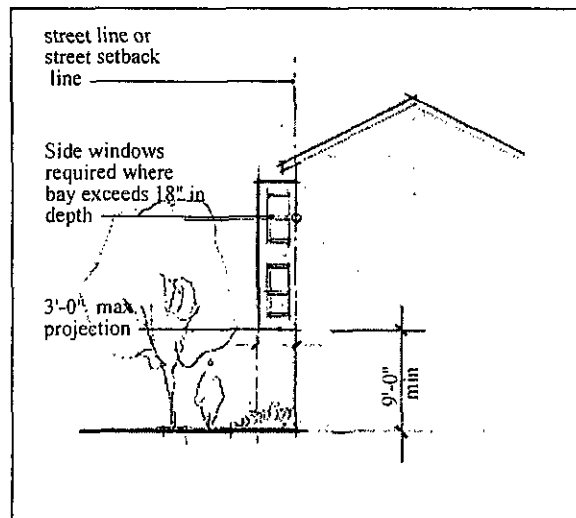

Figure 5.34-1

5.40 Usable Open Space for Residential Uses

Statement of Intent

The intent of the standards set forth in this section is to ensure provision of open areas to serve the residents' need for outdoor leisure and recreation areas.

Applicability

The following standards apply to all residential uses.

General Standards

1. On each lot containing Residential Facilities, usable open space shall be provided as set forth in *Table 5.10-1 Development Standards Summary*.
2. A minimum of 30% of the required usable open space shall be group open space. The remainder of required usable open space may consist of either group or private open space, or a combination of the two.
3. Location of group usable open space:
 - a. No more than fifty percent (50%) of the required group open space shall be located on the roof of a building.
4. Private usable open space shall be adjacent to and readily accessible from the living unit served.
5. Size and shape: An area of contiguous space shall be of such size and shape that a rectangle inscribed within it shall have no dimension less than the dimensions shown in the following table:

a. Private usable open space:	5 Feet
b. Group usable open space:	10 Feet
6. Except as otherwise provided in the standards set forth in this section, the requirements for accessibility, openness usability, and enclosure shall be as set forth in Section 17.99.050 (s-17 zone) of the Planning Code.
7. The requirements for Landscaping at usable open space shall be as set forth in Section 17.99.060 (s-17 zone).

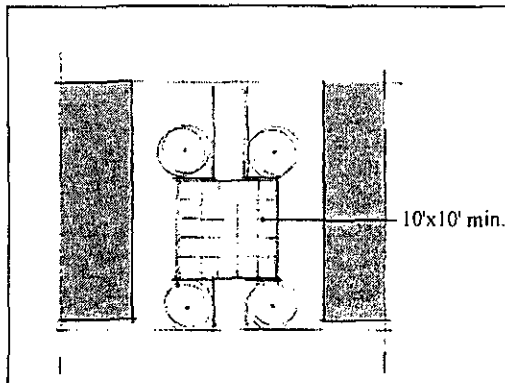

Group Open Space

Figure 5.40-1

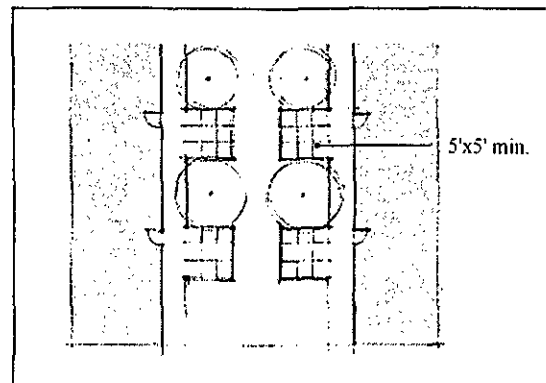

Private Open Space

Figure 5.40-2

5.41 Minimum Separation Between Opposite Walls on the Same Lot

Statement of Intent

The intent of the standards set forth in this section is to ensure that all occupied spaces have reasonable access to light and air.

Applicability

The following standards apply to all uses.

Exceptions

The locations and conditions indicated below are exempt from the standards set forth in this section:

1. Opposite walls of existing buildings

General Standards

1. The minimum separation between opposite walls on the same lot containing windows of habitable rooms shall be equal to the average height of the two opposite walls containing those windows. See *Figure 5.41-1*
2. The minimum allowable separation is twelve (12) feet
3. The maximum required separation is thirty (30) feet, except as indicated in item 4.
4. Where any Opposite wall exceeds 50 feet in height, the maximum required separation is forty (40) feet.
5. Self-supporting bay windows located not less than nine (9) feet above the lowest point of either opposite wall are allowed to project a maximum of three (3) feet into the required separation provided that a minimum separation of twelve (12) feet is maintained from the face of bay and the opposite wall or opposite bay.
6. The total area of bays projecting into the minimum separation shall not exceed 50% of the wall area of either wall.
7. Except as otherwise provided in the standards set forth in this section, the requirements for projections into required separation shall be as set forth in Section 17.108.130 of the Planning Code.

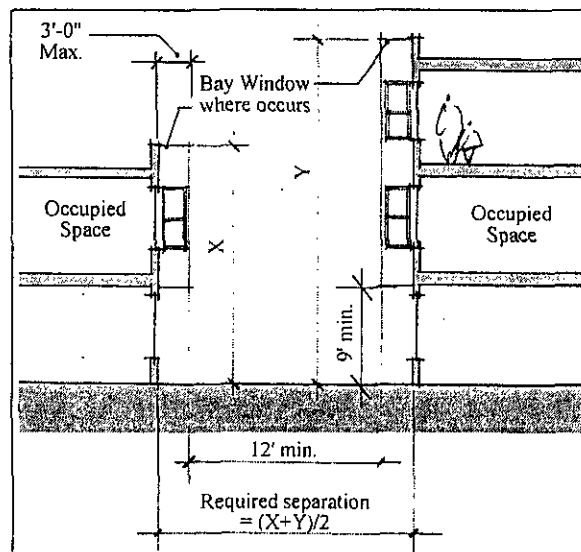

Figure 5.41-1

5.50 Required Off-Street Parking

Statement of Intent

The intent of the required off-street parking standard is to require adequate off-street parking for the intended activity.

Applicability

The following standards apply to all uses.

General Standards

1. Residential Uses: Off-street parking for Residential Uses shall be provided as set forth in Table 5.10-1.
2. Non-Residential Uses: Off-street Parking for Non-residential Uses shall be provided as set forth in Table 5.50-1, below:

Table 5.50-1		
Civic Activity	Minimum Total Floor Area for Which Parking is Required	Requirement
A. Essential Service. Limited Childcare.	No Minimum.	No Spaces required
B. Community Assembly: Temporarily nonprofit festivals.	No Minimum.	A number of spaces to be prescribed by the Director of City Planning pursuant to Section 17.116.040
Private non-profit clubs and lodges.	No Minimum.	No Spaces required.
Churches and all other.	3,000 Square Feet	One space for each 20 seats or for each 150 square feet area where seats are not fixed, in principal meeting rooms.
C. Community Education: high schools.	No Minimum	One Space for each three employees plus one space for each 10 students of planned capacity.
D. Nonassembly Cultural Administrative.	10,000 square Feet	One space for each 1,400 square feet of floor area.
E. Health Care: hospitals.	3,000 Square Feet.	One space for each staff or regular visiting doctor.
Clinics.	3,000 Square Feet.	One space for each staff or regular visiting doctor.
All others.	3,000 Square Feet.	One space for each staff or regular visiting doctor.
F. Utility and Vehicular.	10,000 Square Feet.	One space for each vehicle used in connection with activities.
Commercial Activity	Minimum Total Floor Area for Which Parking is Required	Requirement
A. General Food Sales, Convenience Market, Alcoholic Beverages Sales.	3,000 Square Feet	One space for each 450 square feet of floor area.
B. Convenience Sales and Service Mechanical or Electronic Games. Medical Service. General Retail Sales, except when sales are primarily of bulky merchandise such as furniture or large appliances. General Personal Service. Consumer Laundry and Repair Service, except when services consist primarily of repair or cleaning of large items such as furniture or carpets. General Wholesales, whenever 50 percent or more of all sales on the lot are at retail. Undertaking Service	3,000 Square Feet	One space for each 900 square feet of floor area.
C. Consultative and Financial Services. Administrative. Business Supply, whenever 50 percent or more of all sales on the lot are at retail. Research Service.	3,000 Square Feet	One space for each 900 square feet of floor area.
D. Retail Business Supply, whenever less than 50 percent of all sales on the lot are at retail. General Wholesale Sales, whenever less than 50 percent of all sales on the lot are at retail. Construction Sales and Services. Automotive Sales and Service.	3,000 Square Feet	One space for each 1,000 square feet of floor area. or for each three employees, whichever requires fewer spaces.

Table 5.50-1		
Commercial Activity	Minimum Total Floor Area for Which Parking is Required	Requirement
Automotive Sales, Rental and Delivery.		
E. Group Assembly.	Total of 75 Seats in indoor places of assembly with fixed seats, or 750 square feet of floor area in dance halls or other places of assembly without fixed seats, or 5,000 square feet of outdoor assembly areas.	One space for each eight seats in indoor places of assembly with fixed seats, plus one space for each 80 square feet of floor area in indoor places of assembly with out fixed seats, plus a number pf spaces to be prescribed by the Director of City Planning, pursuant to Section 17.116.040, for outdoor assembly areas.
F. Transient Habitation.	No Minimum.	One space for each unit in a motel and one space for each two units in a hotel.
G. General Retail Sales, whenever sales are primarily of bulky merchandise such as furniture appliances. Consumer Laundry and Repair Service, whenever services consist primarily of repair or cleaning of large items such as furniture or carpets. Animal care.	3,000 Square Feet	One space for each 1,000 square feet of floor area.
H. Fast-Food Restaurant.	2,000 Square Feet	One space for each 300 square feet of floor area.

5.51 Dimensional Requirements for Off-Street Parking

Statement of Intent

The intent of the standards set forth in this section is to ensure that the dimensions of stalls and maneuvering areas are adequate to serve the needs of the users.

Applicability

The following standards apply to required off-street parking spaces serving all uses.

General Standards for Parking Serving Residential Uses

1. The following subsections of Section 17.94 (S-12 Residential Parking combining zone regulations) of the Planning Code shall apply to the Wood Street Zoning District.
 - a. Section 17.94.060 Parking Spaces (Items A,B & C), with additional standards indicated below.
 - b. Section 17.94.070 Maneuvering aisles (all)
 - c. Section 17.94.090 Other Dimensional Requirements (all)

Additional Standards For Parking Serving Residential Uses

2. A standard parking stall size of 8'x17' may be provided for all required spaces serving residential uses.
3. In parking garages where the layout of stalls conforms to a regular grid of structural columns, the dimensions indicated in *Figure 5.51-1* shall be considered to provide the minimum allowable clearance related to the obstruction created by the structural columns.

Standards For Parking Serving Uses Other Than Residential Uses

4. Required dimensions for parking serving activities other than residential shall be as set forth in Section 17.116 of the Planning Code.

Standards For Other Parking Arrangements

5. Mechanical Parking Systems:
 - a. Mechanical parking systems including vertical stacking systems are allowed subject to approval by the Building Official. The Parking Stall Dimension for such systems shall be as required for safe operation of the systems.
6. Tandem Parking:
 - a. Tandem parking is allowed provided at least one independent parking space is provided for each dwelling unit.

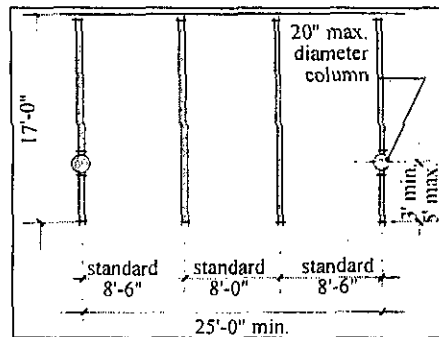

Residential Parking
Parking Garage, minimum dimensions *Figure 5.51-1*

5.52 Joint Use Parking

Statement of Intent

The intent of the joint use parking standard is to provide for efficient and effective joint use parking.

Applicability

The following standards apply to all uses.

General Standards

1. Residential uses shall be allowed to utilize off-street parking serving other uses, provided the following conditions are met.
 - a. Joint use parking shall be located on the same lot or within three hundred (300) feet of the uses served.
 - b. Joint use parking spaces are guaranteed to be available for residential use between the hours of 6:00 PM and 8:00 AM.
 - c. Joint use parking shall be arranged to provide security and access at least equal to other required off-street parking.
 - d. Joint use parking arrangements shall be included as Conditions of Approval for the development project.
2. Joint use parking shall not account for more than thirty percent (30%) of the required off-street residential parking.

5.53 Curb Cuts

Statement of Intent

The intent of the curb cuts standards is to ensure that the width and spacing of curb cuts provides for efficient on-street parking and is consistent with a pedestrian-oriented development project.

Applicability

The following standards apply to all curb cuts at street lines except as specified below.

Exceptions

The locations and conditions indicated below are exempt from the standards set forth in this section:

1. Existing curb cuts serving existing buildings

General Standards

1. The maximum total allowable width of an individual curb cut is twenty-four (24) feet.
2. The distance between curb cuts on public streets shall not be less than twenty-four (24) feet.

Standards for Wood Street Overlay Zone

3. In the Wood Street Overlay Zone, the aggregate width of curb cuts shall not exceed 20% of the lot frontage.
4. The distance between curb cuts shall not be less than forty-four (44) feet.

5.54 Off-Street Loading Requirements

Applicability

The following standards apply to uses except as specified below.

Exceptions

The locations and conditions indicated below are exempt from the standards set forth in this section:

1. Existing loading areas serving existing buildings

Statement of Intent

The intent of the off-street loading standards is ensure that all development projects have adequate access to loading areas.

General Standards

1. Designated loading zones shall be provided at Public Access Areas subject to approval by the Planning Official.
2. There is no requirement for off-street loading areas other than those provided at Public Access Areas.

5.60 Location and Screening of Surface Parking

Applicability

The following standards apply to all surface parking areas except as specified below.

Exceptions

The locations and conditions indicated below are exempt from the standards set forth in this section:

1. Facilities located adjacent to elevated roadways

Statement of Intent

The intent of these standards is to ensure that surface parking shall be screened from view from the public rights-of-way or Public Access Areas.

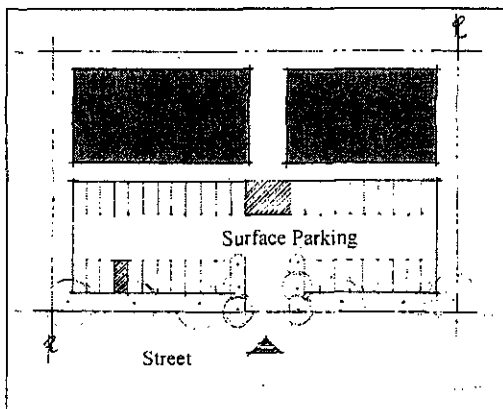

Figure 5.60-1

Not Allowed

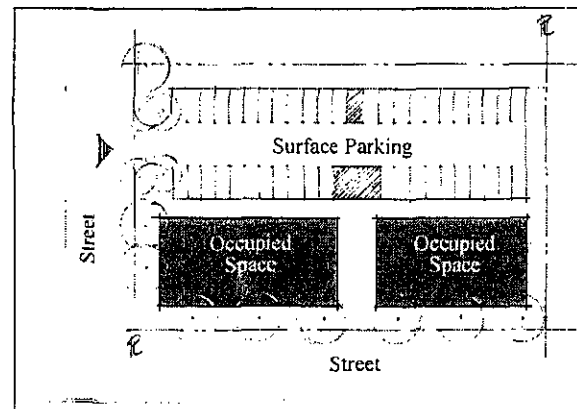

Figure 5.60-2

Allowed

General Standards

1. Surface parking areas containing more than four stalls are not allowed less than twenty (20) feet from a street line or street setback line unless each of the following conditions is met. See *Figure 5.60-1*.
 - a. The width of the surface parking does not exceed seventy (70) feet, measured from curb to curb
 - b. The surface parking is screened from view from the Public Right-of-way or Public Access Area by one of the following means.
 1. A solid fence or wall with a minimum height of four (4) feet located between the street line and the parking area with maximum transparent area of thirty percent (30%).
 2. An open fence with a minimum height of four (4) feet with adjoining planting that will create an opaque screen at least equal in height to the fence within three years of planting.
2. Individual surface parking areas less than twenty (20) feet from the street line or street setback line must be separated by a minimum of sixty (60) feet. The intervening space shall contain occupied building frontage, usable open areas, or a combination of the two.

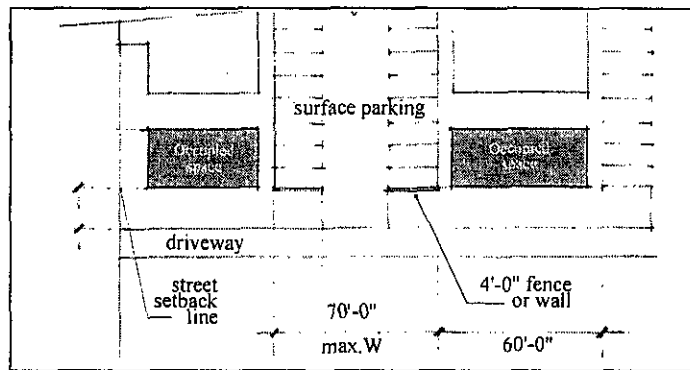

Figure 5.60-1

Standards for Wood Street Overlay Zone

3. No surface parking is permitted within the Wood Street Overlay Zone.

Standards for Frontage Road Overlay Zone

4. Surface parking is allowed in the Frontage Road Overlay Zone subject to the following limitations:
 - a. The width of surface parking in the Frontage Road Overlay Zone shall not exceed two hundred (200) feet or an aggregate maximum of fifty percent (50%) of the street frontage of any lot, whichever is less.
 - b. Surface parking in the Frontage Road Overlay Zone shall be screened as indicated in item 1b above.

5.61 Shade Trees at Surface Parking Areas

Statement of Intent

The intent of these standards is to ensure the provision of shade trees at surface parking areas.

Applicability

The following standards apply at all off-street surface parking areas containing 10 or more stalls.

General Standards

1. For every eight (8) parking spaces, a minimum of one tree shall be provided.
2. All required trees shall be 15 gal. minimum size at time of planting and shall be provided with an automatic irrigation system.
3. Tree wells shall be a minimum of 9 square feet in an area, measured to the inside face of curb or paving.
4. Required trees shall be located within the parking area and shall be distributed evenly. See *Figure 5.61-1*
5. All required trees shall be protected from vehicular traffic by a curb, bollard or metal tree guard.
6. Trees may be omitted where a covered structure is provided at parking stalls.

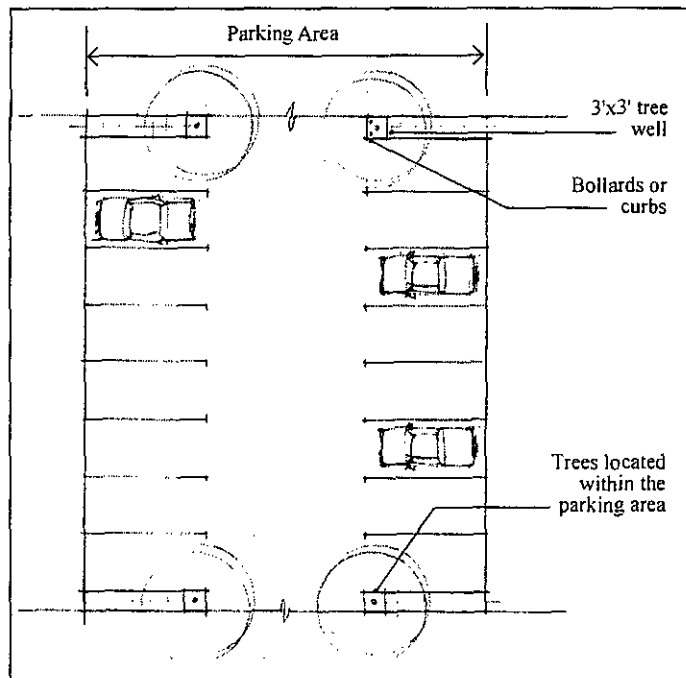

Figure 5.61-1

5.62 Location and Screening of Tuck-under Parking

Statement of Intent

The intent of these standards is to limit the impact of tuck-under parking on the street frontage.

Applicability

The following standards apply to all Residential Uses except as specified below.

Exceptions

The locations and conditions indicated below are exempt from the standards set forth in this section:

1. Existing Buildings
2. Adjacent to elevated roadways

General Standards

1. Tuck-under parking is not allowed less than twenty (20) feet from the street line or street setback line unless the following conditions are met.
 - a. The width of the tuck-under parking does not exceed seventy (70) feet, measured from end of stall to end of stall, or curb to curb. See *Figure 5.62-1*
 - b. The tuck-under parking area is screened by a wall or fence with a minimum height of six (6) feet. Openings in the wall or fence shall not exceed 40% of the area of the wall or fence.
2. Individual tuck-under parking areas located less than twenty (20) feet from the street line or street setback line must be separated by a minimum of sixty (60) feet. The intervening space shall contain occupied building frontage, usable open areas, or a combination thereof.

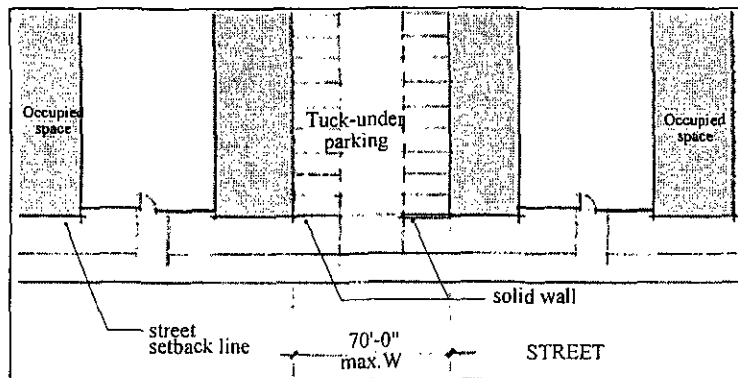

Figure 5.62-1

Standards for Wood Street Overlay Zone.

3. No tuck-under parking is permitted within the Wood Street Overlay Zone.

Standards for Frontage Road Overlay Zone

4. Tuck-under parking is allowed in the Frontage Road Overlay Zone subject to the following requirements.
 - a. Tuck-under parking shall be screened from view from the public right-of-way by a wall or fence with a minimum height of six (6) feet. Openings in the wall shall not exceed forty percent (40%) of the area of the wall or fence.
 - b. Occupied space or usable open space shall be located above the tuck-under parking.

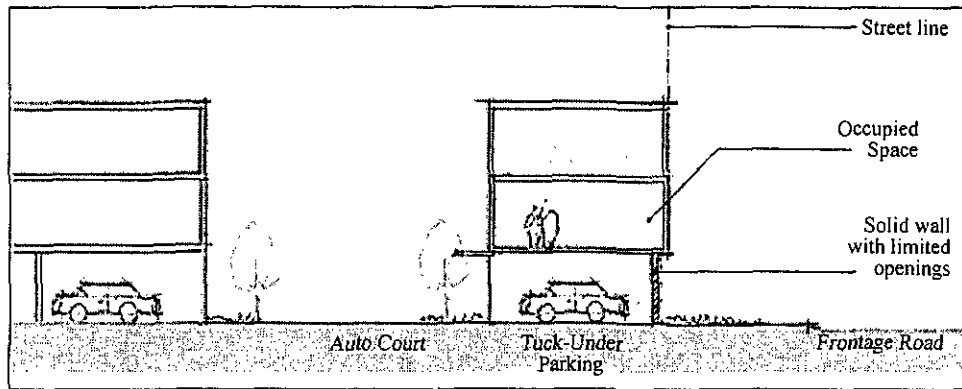

Figure 5.62-2

5.63 Location & Screening of Parking Garages

Statement of Intent

The intent of standards related to the location and screening of parking garages is to ensure that parking garages are screened from the street frontage. Three acceptable strategies for screening structured parking adjacent to the street line or street setback line are set forth below.

Option I - Below-grade parking with occupied space at the ground floor, See *Figure 5.63-1*

Option II - Occupied space at the ground floor, with parking above. See *Figure 5.63-2*

Option III - Parking garage screened by a "liner" of occupied space with minimum depth of twenty (20) feet. See *Figure 5.63-3*

Applicability

The following standards apply to parking garages containing three or more parking stalls except as specified below.

Exceptions

The locations and conditions indicated below are exempt from the standards set forth in this section:

1. Parking garages developed within the shell of existing buildings
2. Parking garages adjacent to elevated roadways

Reference Section 6.25 for guidelines for parking garage facades.

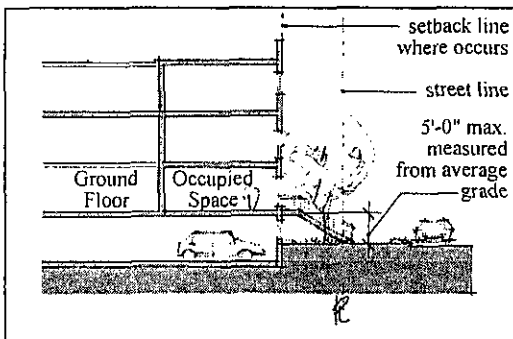

Option I
Below grade parking

Figure 5.63-1

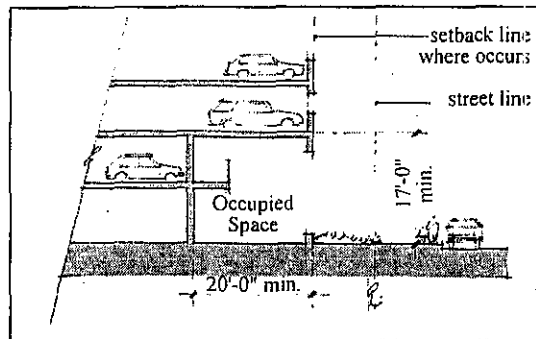

Option II
Parking structure on setback line with occupied space at ground level.

Figure 5.63-2

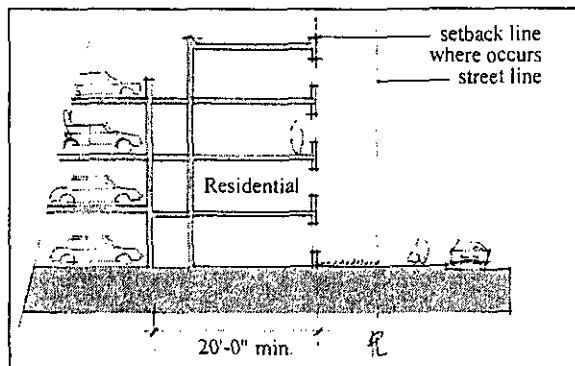

Option III
Residential liner between parking structure public right-of-way (R.O.W.)

Figure 5.63-3

General Standards

1. Ground floor parking garages are not permitted within twenty (20) feet of the street line, except as specifically allowed by other standards set forth in this section.
2. Parking garage frontage may be located at the ground floor and less than twenty (20) feet from the street line or street setback line, provided the width of the garage frontage does not exceed sixty-five (65) feet. See *Figure 5.63-4*.
3. Above grade parking garages are allowed to extend to the street line or street setback line where occupied space is provided at the ground floor with a minimum depth of twenty (20) feet and a minimum height of seventeen (17) feet, measured to top of finish floor above. See *Figure 5.63-2*.
4. Below grade parking garages are allowed less than twenty (20) feet from the street line or the street setback line provided occupied space at least one story in height occurs immediately above. See *Figure 5.63-1*.

Standards for Wood Street Overlay Zone

5. No ground floor parking garages are permitted within the Wood Street Overlay Zone.
6. Vehicular entries to parking garages shall not exceed twenty-four (24) feet in width.
7. No more than two (2) vehicular entries to parking garages may occur from Wood Street within any two-hundred (200) foot distance measured at the street line.

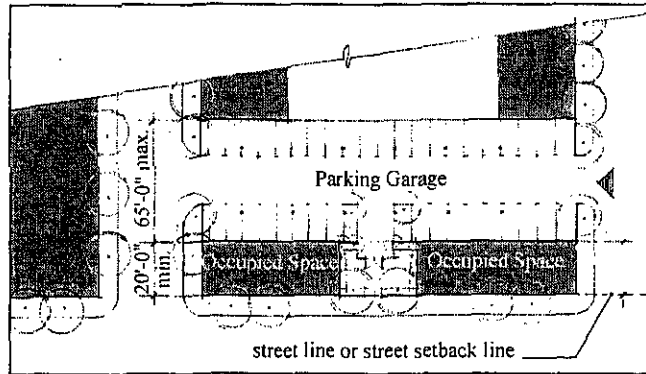
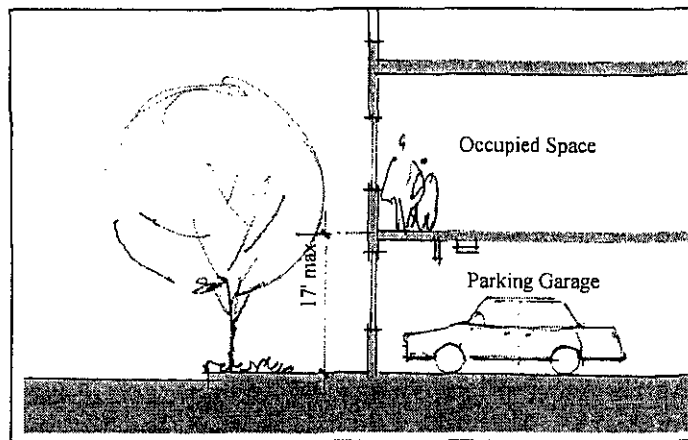

Figure 5.63-4

Standards for Frontage Road Overlay Zone

8. A ground floor parking garage not exceeding one (1) story or seventeen (17) feet in height measured from average exterior grade to the floor above may be located less than twenty (20) feet from the street line, provided occupied space or usable open space is located immediately above.
9. A parking garage or garages not exceeding two (2) stories or twenty-four (24) feet in height may be located less than twenty (20) feet from the street line, provided the aggregate length of the parking garage does not exceed two hundred (200) feet or fifty percent (50%) of the street line of any individual lot, and provided occupied space or usable open space is located immediately above.



Allowable garage frontage
at Frontage Road Overlay Zone

Figure 5.63-5

5.70 Limitations on Signs

Statement of Intent

The intent of these standards is to ensure that the display area of signs is compatible with the proposed development.

Applicability

The following standards apply at all private signs visible from a Public Street or Public Access Area except as specified below.

General Standards

1. All signage shall be subject to the standards set forth in Planning Code Section 17.104.010 *General Limitations On Signs in Residential and Open Space Zones* except as otherwise provided in the following standards.
2. The display area and number of signs shall conform to the limitations set forth in Table 5.70-1, Summary of Signs Standards.
3. For activities with frontage exceeding seventy-five (75) feet on two or more public streets or Public Access Areas, the allowable aggregate display area and allowable number of signs may be doubled.
4. Billboards and other free standing commercial signs are not allowed.

Table 5.70-1 Summary of Signs Standards			
Use Activity	Sign Type	Aggregate Display Surface (square feet)	Allowable Number of Individual Signs
Residential	Home Occupation Signs	1	No signs allowed
Residential Facilities of three or more units		6	1 sign per project
Commercial	Business Sign	15	1 sign for each commercial establishment
Commercial Activities greater than 10,000 SF in floor area	Business Sign	35	2 signs for each commercial establishment
All Uses	Development Sign	75	1 sign for each separate development project
	Realty Sign	6	1 sign per project
Civic Activities	Civic Sign	1	1 sign per civic use
Civic Activities greater than 10,000 SF in Floor Area	Civic Sign	30	2 signs for each civic establishment

5.80 16th Street Station and 16th Street Signal Tower

Statement of Intent

The intent of these standards is to ensure that renovation of the Station and the scale and location of adjacent development is consistent with the Station's status as a City of Oakland Landmark.

Applicability

The following standards apply to the 16th Street Station located in Development Area 5 or to the 16th Street Signal Tower located in Development Area 6, as specified below.

General Standards

1. Any renovation, modification or addition to the Station shall conform with the standards set forth in Section 17.102.030 of the Planning Code "Special regulations for designated landmarks" and to the Secretary of the Interior's Standards for Rehabilitation of Historic Structures.
2. Any renovation, modification or addition to the station will be subject to review by the Landmarks Preservation Advisory Board, as set forth in Section 17.136.040 of the Planning Code.
3. Any re-use of the 16th Street Station shall include stabilization and repair of existing exterior materials to improve the exterior appearance and to ensure a weather tight building envelope.

Standards for Additions to 16th Street Station

1. Additions to the Station shall not exceed a maximum height of thirty-five (35) feet as set forth in Table 5.10-1, Development Standards Summary.
2. No addition shall be made to the 16th Street Station on the facade facing the 16th Street Plaza or on the southern facade facing the 16th Street Public Access Area.

Standards for New Buildings adjacent to the 16th Street Signal Tower

1. Additions to the Signal Tower are not permitted.
2. New structures shall be set back from the existing Signal Tower a minimum distance of fifteen (15) feet.

5.90 16th Street Plaza

Statement of Intent

The intent of these standards is to ensure that the 16th Street Station Plaza (Development Area 9) is developed as a publicly accessible outdoor space that provides an appropriate foreground setting for the 16th Street Train Station.

Applicability

The following standards apply to Development Area 9, also known as the 16th Street Plaza.

General Standards

1. No enclosed structures of any kind are allowed. (This includes no restrooms, storage spaces, etc.)
2. Site Development shall not adversely affect the special character, interest or value of the 16th Street Train Station and its site. (From Section 17.102.030)
3. Site lines shall be maintained across the Plaza between Wood Street and the façade of the main hall at the 16th Street Train Station.
4. The Development Area shall be landscaped with an appropriate dust free surface that may include a combination of paving and planting that is suitable for walking, sitting and similar activities.
5. Site development shall accommodate and promote the following specific activities.
Passive recreation
Occasional activities such as farmers-markets and craft-fairs
Vehicular drop at main entry to 16th Street Train Station
Occasional use of open space to accommodate overflow parking serving activities at the 16th Street Station
6. Site development shall not accommodate or promote the following specific activities
Active recreation
Overnight camping
7. The total area exclusively dedicated to vehicular circulation and parking shall not exceed 25% of the Development Area.
8. There shall be no obstructions above the plaza except for statues, awnings, trellises or similar devices to enhance its usability.
9. Site lighting shall be provided in accordance with City of Oakland Standards for Public Rights-of-way.
10. An average of one shade tree shall be provided for every 3,000 SF of Development Area. Trees shall be not be less than 15 gallon at time of planting.
11. All planting shall be provided with an automatic irrigation system.
12. All planting and irrigation shall be permanently maintained in good condition and, whenever necessary, replaced with new materials.

6.00

DESIGN GUIDELINES

6.10 Introduction to Design Guidelines

Introduction

The Design Guidelines establish the design parameters for the Wood Street Zoning District and address aspects of building and site design not otherwise regulated by the Development Standards. Each development project within a Development Area shall be evaluated in terms of how the design satisfies the design intent set forth in the Design Guidelines, in accordance with Section 3.30 above (Final Development Plan/Final Design Review). Subject to determination by the Planning Director, design solutions may be approved on the basis of conformance with the intent of the Design Guidelines without conforming to the specific recommendations set forth in those guidelines.

Applicability and Exceptions

The Design Guidelines are generally applicable to all Development Areas. Each set of guidelines includes a statement which identifies any limits of applicability within a Development Area as well as any locations or conditions that are exempt from the guidelines contained in that section.

Guidelines - Encouraged, Discouraged and Not Allowed

As a means of illustrating intent, certain guidelines provide examples under the categories of “encouraged,” “discouraged” or “not allowed”. These examples are representative and are not an exhaustive list of all possible examples in each category. Elements that are indicated as discouraged may be allowed subject to the determination by the Planning Director that a certain design solution in a particular application is consistent with the intent of that Guideline.

Optional Prescriptive Guidelines

For certain guidelines, a set of optional prescriptive guidelines is provided. Design solutions which adhere to the prescriptive guidelines shall be deemed to have met the intent of the Design Guidelines. Design solutions which do not adhere to the prescriptive guidelines must be consistent with the intent of the Design Guidelines, subject to determination by the Planning Director.

Guidelines for specific locations

Guidelines applicable to specific Overlay Zones or Development Areas are included in some sections. In case of conflict, guidelines applicable to a specific Overlay Zone or Development Area shall take precedence over general guidelines.

6.20 Architectural Character

Applicability

The following guidelines apply to all Development Areas.

General Guidelines

1. Each development project shall by use of massing, articulation, materials and detail establish a coherent, integrated architectural character that is consistent within each development project. All built aspects of the development project shall be considered as contributing to the architectural character of the development project, including but not limited to; site structures and furnishings, exterior lighting, paving and signage.
2. Buildings are not restricted to any specific architectural style. Within the overall scope of the Wood Street Zoning District, a variety of architectural styles are encouraged as a means of enhancing the mixed-use, urban character of the development project.

6.21 Pedestrian Connections

Applicability

The following guidelines apply to all Development Areas except as specified below.

Exceptions

The locations or conditions indicated below are exempt from the guidelines contained in this section:

1. Existing buildings
2. Development Area 8
3. Frontage Road Overlay Zone
4. Plaza Overlay Zone
5. Adjacent to elevated roadways

General Guidelines

1. Provide multiple street facing openings and pedestrian entries into the site. Particular emphasis should be placed on visual and pedestrian connections at Wood Street. See Figure 6.21-1.

Encouraged

- a. Multiple pedestrian connections with Public Streets or Public Access Areas
- b. Ground level views into the site from the public streets or Public Access Areas
- c. Ground level pedestrian lanes or auto/pedestrian lanes that subdivide larger Development Areas.

Discouraged

- a. Building frontage at street lines or street set back lines exceeding 200 feet in length without provision of ground level pedestrian access and views into the interior portion of the development site.
2. Security gates and fences at pedestrian entries should have an average transparency of 50% or greater.

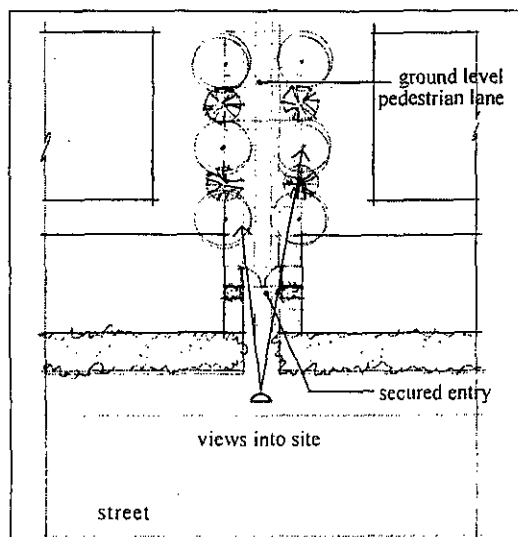

Figure 6.21-1, (Illustrative Only)

6.23 Building Massing

Applicability

The following guidelines apply to portions of buildings located within sixty (60) feet of the street line or street setback line and greater than two (2) stories or twenty five (25) feet in height except as specified below.

Exceptions

The locations or conditions indicated below are exempt from the guidelines contained in this section:

1. Building frontage on 10th Street
2. Building frontage on the 20th Street Public Access Area
3. Building frontage adjacent to elevated roadways
4. Existing buildings
5. Commercial uses at Development Area 8

General Guidelines

1. Massing should reduce the visual scale of large development projects and to respond to specific adjoining conditions.

Encouraged

- a. Articulation of separate building volumes.
- b. Building massing that emphasizes corner locations
- c. Building massing that emphasizes major entry points into the site
- d. Creation of a varied building silhouette by incorporating significant changes in massing at the roof lines

Guidelines for Wood Street Overlay Zone

1. Significant changes in building massing are strongly encouraged to reduce the perceived scale of buildings fronting Wood Street. See *Figure 6.23-1*.
 - a. A significant change in massing is defined as a building offset having a width and depth of not less than eight (8) feet and a height of not less than one story.

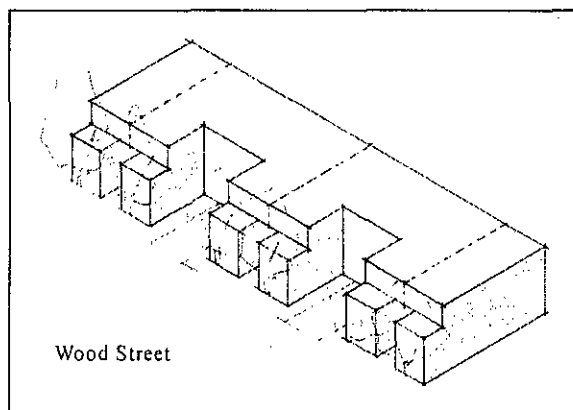

Figure 6.23-1, (Illustrative Only)

6.24 Building Articulation

Applicability

The following guidelines apply to all building facades located parallel to and less than twenty (20) feet from a street line or street setback line except as specified below.

Exceptions

The locations or conditions indicated below are exempt from the guidelines contained in this section:

1. Building frontage on 10th Street
2. Building frontage on the 20th Street Public Access Area
3. Building frontage adjacent to elevated roadways
4. Existing buildings
5. Commercial uses at Development Area 8

General Guidelines

1. Building facades shall be articulated by means of recesses, changes in plane, bays, projecting elements, variations in exterior finishes or a combination thereof. Articulation strategies may include emphasizing groupings of dwelling units or occupied spaces, establishing vertical and horizontal rhythms, creating a varied building silhouette, adding visual accents and similar architectural strategies.

Prescriptive Guidelines (Optional)

1. Any building plane greater than sixty (60) feet in width and more than one story in height shall be articulated by a recess or projection extending at least two stories in height with a minimum width of four (4) feet and a minimum depth of two (2) feet. See *Figure 6.24-1*
2. The maximum length for a single building plane may be increased to one hundred (100) feet when building articulation is provided in the form of a recess or projection extending at least two stories in height with a minimum width of two (2) feet, a minimum depth of one and one half (1 1/2) feet, and occurring a minimum of three times within any one hundred (100) foot length of building facade. See *Figure 6.24-2*
3. The allowable length of a single uninterrupted plane may be doubled at the first story.

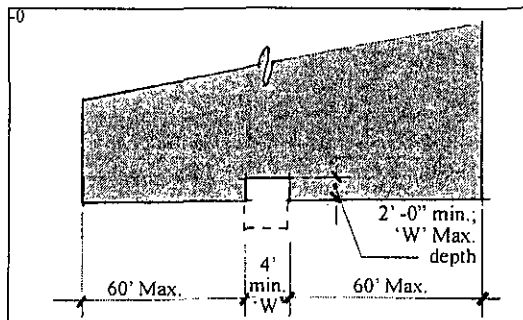

Figure 6.24-1, (Illustrative Only)

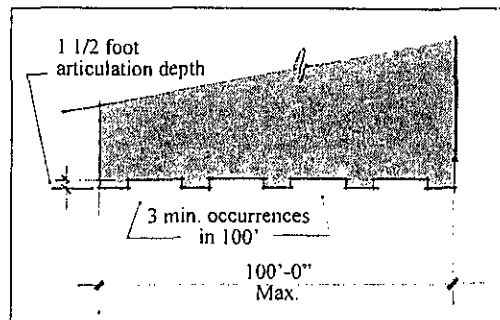

Figure 6.24-2, (Illustrative Only)

6.25 Parking Garages Facades

Applicability

The following guidelines apply to all parking garage facades visible from and located within sixty (60) feet of a street line or street setback line except as specified below except as specified below.

Exceptions

The locations indicated below are exempt from the guidelines contained in this section:

1. Building frontage on 10th Street
2. Building frontage on 20th Street
3. Building frontage located adjacent to and below elevated roadways.
4. Facades of garages that will be concealed by subsequent phased construction.

Coordination with Development Standards

Refer to Section 5.64 of the *Development Standards* for limitation on the location of parking garages.

General Guidelines

1. The architectural character of the parking garage facade shall be integrated with the facade of the occupied space served by the garage. See *Figure 6.25-1*
 - a. Patterns of openings at garage facades should be similar in rhythm and scale to openings at the occupied spaces served by the garage.
 - b. Garage facades should incorporate awnings, canopies, sunscreens, planters, ornamental railings and other elements to provide a visual richness comparable to that of facades at the occupied space served by the garage.
2. Transparent openings at garage facades, including unglazed openings or openings with clear glazing shall not exceed 50% of the wall area visible from the exterior at any story of a parking garage.
 - a. There is no limitation on the area of permanent translucent materials at garage facades, such as glass block or etched glazing.
3. Lighting at parking garages shall be located or screened to prevent direct view of light source from streets or public access areas, to the greatest degree practical.

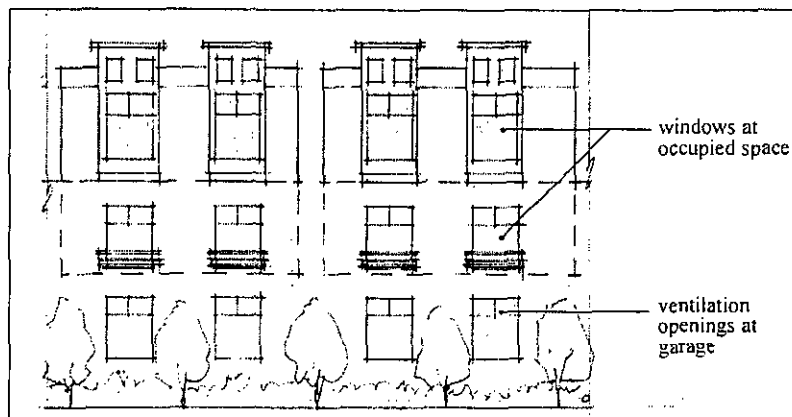

Figure 6.25-1

6.26 Balconies

Applicability

The following guideline applies to balconies at all buildings.

General Guidelines

1. Where provided, balconies shall be visually integrated with the architectural character of the project and shall not be the predominant element on any facade facing the street line. See *Figure 6.26-1*

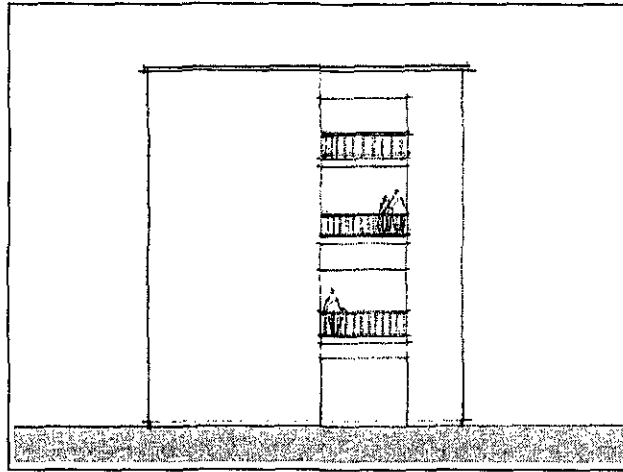

Figure 6.26-1, (Illustrative Only)

6.27 Awnings & Canopies

Applicability

The following guidelines apply to all buildings or portions of buildings parallel to and located less than twenty (20) feet from a street line or street setback line except as specified below.

Coordination with Development Standards

Refer to Section 5.32 of the Development Standards for requirements related to building entries at building frontage.

General Guidelines

1. Storefront awnings and/or canopies are encouraged at ground level commercial locations to provide articulation to the building facade, sun and rain protection to pedestrians, and shield large window areas from glare.
2. Awnings and canopies shall be divided into sections that relate to and emphasize vertical elements of the building facade.
3. Awnings and canopies shall align with horizontal datum lines at the building facade.
4. Awnings and canopies shall be constructed of durable materials. Fabrics designed for exterior use are acceptable.

Guidelines for Plaza Overlay Zone

5. At building facades within the Plaza Overlay Zone, a consistent pattern of awnings or canopies shall be provided at the ground floor of each facade fronting the plaza.
 - a. These awning or canopy treatments are not required to be consistent with those at other buildings fronting the plaza.
 - b. This requirement does not apply where an arcade, porch or other sheltering architectural element is provided at the ground floor.

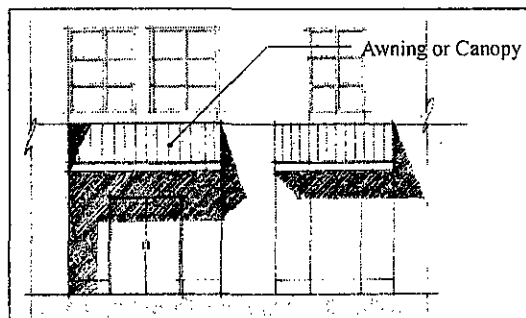

Figure 6.27-1. (Illustrative Only)

6.30 Windows

Applicability

The following guidelines apply to all buildings or portions of buildings visible from and within sixty (60) feet of the public rights-of-way except as specified below.

Exceptions

The locations or conditions indicated below are exempt from the guidelines contained in this section:

1. Existing Buildings

General Guidelines

1. The proportion and subdivision of typical windows should reflect the overall proportion and character of the building. Exceptions for special windows are allowed.
2. Window materials, trim (if any), and detailing should be of good quality and consistent with the architectural character of the building and compatible with the other exterior materials.
3. Windows set flush with cement plaster (stucco) finish without provision of trim, projecting sills, or other perimeter detailing are discouraged
4. Glazing shall be transparent to the greatest degree practical

Encouraged: clear glazing, Low-E glazing where needed for sun control

Discouraged: tinted glazing except at special locations, or at commercial occupancies located above the ground floor

Not Allowed: reflective glazing, except at spandrels or other special conditions consistent with overall architectural design

5. Window grills or security screens are discouraged in all Development Areas, particularly at locations less than twenty (20) feet from a street line or street setback line.
 - a. Where necessary due to specific security concerns, window grills or security screens shall be fabricated of high quality materials and be designed as an integral part of the architectural character of the development project

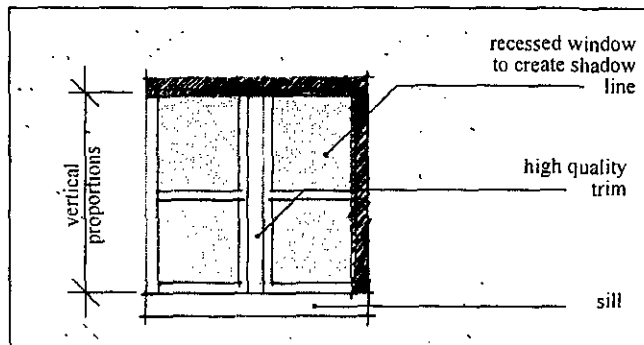

Example of window articulation

Figure 6.30-1, (Illustrative Only)

6.31 Garage Doors

Applicability

The following guidelines apply to all garage doors visible from and located less than sixty (60) feet from a street line or street setback line, and serving parking garages containing three or more parking spaces except as specified below.

Exceptions

The locations or conditions indicated below are exempt from the guidelines contained in this section:

1. Existing Buildings

Coordination with Development Standards

Refer to *Section 5.63 of the Development Standards* for limitations on the location of garage doors within in the Wood Street Overlay Zone.

General Guidelines

1. Automatic, motor operated garage doors shall be provided at all vehicular entries to parking garages
2. Garage door openings shall be aligned with windows, bays or other architectural elements to create an integrated composition consistent with the overall architectural character of a development project. See *Figure 6.31-1*
3. Garage doors shall be recessed a minimum of one (1) foot from the face of the adjoining building facade.
4. Garage doors shall be constructed of high quality durable materials:

Encouraged: Single panel sliding-type garage doors
Sectional overhead doors

Discouraged: Residential grade garage doors
Single panel overhead doors

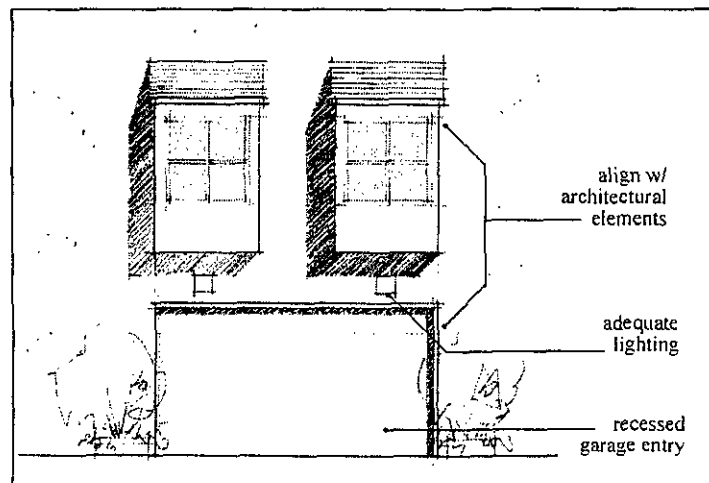

Example of garage door articulation

Figure 6.31-1. (Illustrative Only)

6.32 Service Access

Applicability

The following guidelines apply to all ground level service doors or gates visible from and located less than twenty (20) feet from a street line or street setback line, and which provide access to waste handling areas, electrical or mechanical equipment, gas or electric meters, or other non-occupied service spaces except as specified below.

Exceptions

The locations or conditions indicated below are exempt from the guidelines contained in this section:

1. Building frontage adjacent to elevated roadways
2. Existing service access doors at existing buildings.

General Guidelines

1. All service doors and gates shall be designed as integral elements of the building design.
2. The aggregate width of service doors shall not exceed fifteen (15) feet within any 60 feet of street frontage
3. Doors exceeding thirty (30) square feet in area (such as doors to waste handling areas or electric transformers) shall be recessed a minimum of 9 inches from the primary building plane
4. Service doors or gates shall not allow any view into space served. Louvers required for venting or ventilation purposes are acceptable provided they do not allow visibility into service areas.

Guidelines for Wood Street & Plaza Overlay Zones

1. Service openings facing Wood Street are discouraged, where service openings are necessary they shall be subject to the following limitations.
 - a. The maximum combined width of the service access openings shall not exceed eight (8) feet in any 60 feet of street frontage
 - b. No individual service access opening shall exceed eight (8) feet in width

6.33 Underground Utility Connections

Applicability

The following guidelines apply to all Development Areas, except as specified below.

Exceptions

The locations or conditions indicated below are exempt from the guidelines contained in this section:

1. Existing buildings

General Guidelines

All utility lines serving lots within the Wood Street Zoning District shall be underground to point of entry at building, including electrical, telephone, data and cable services.

6.34 Screening of Equipment

Applicability

The following guidelines apply to all Development Areas except as specified below.

Exceptions

The locations or conditions indicated below are exempt from the guidelines contained in this section:

1. Adjacent to elevated roadways

General Guidelines

1. All equipment located within twenty (20) feet of a street line or adjoining setback line shall be screened by one of the following means. (Refer to 3.40 *Definition of Terms* for definition of equipment).
 - a. By enclosure entirely within the structure of the building with access provided by opaque service access door. (A portion of Electric meters may be exposed to allow reading of meter without opening door.)
 - b. By enclosure in a below grade vault or structure
 - c. By provision of a fence or wall with a maximum average transparency of 50 percent. The top of the fence or wall shall be at least equal in height to the equipment screened, but shall not exceed eight (8) feet maximum in height. See *Figure 6.34-1*,
 - d. By combination of an open fence and adjoining planting that will reach a height sufficient to screen the equipment within three years

Exceptions

The following equipment is not required to be screened.

- a. Residential gas meters serving individual dwelling units in groups not exceeding four meters.
 - b. Individual commercial gas meters.
 - d. Back flow preventers for irrigation systems not exceeding 2" nominal size.
2. Equipment located more than twenty (20) feet from a street setback line or street setback line shall be integrated into the overall building and site design.
 3. All equipment located on the roof of a building shall be screened by one of the following means.
 - a. By location such that no portion of the equipment is visible from the street.
 - b. By provision of a screening device consistent with the architectural character of the development project and with an open area not exceeding forty (40) percent that screens equipment visible from the street.

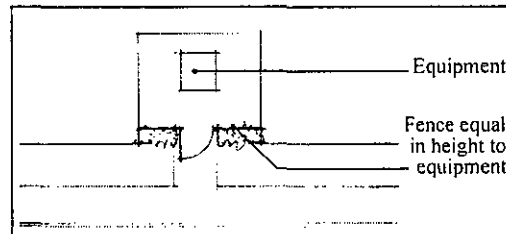

Figure 6.34-1, (Illustrative Only)

6.35 Mechanical Penetrations at Facades and Roofs

Applicability

The following guidelines apply to all Development Areas except as specified below.

Exceptions

The locations or conditions indicated below are exempt from the guidelines contained in this section:

- I. Existing Buildings

General Guidelines

1. The following guidelines apply to roof penetrations at buildings located less than sixty (60) feet from a street line or street setback line.
 - a. Appliance vents, exhaust fans, and similar roof penetrations shall be located so as to not be visible from the street, to the greatest degree practical.
 - b. Where visible from street, roof penetrations shall be aligned to present an organized appearance.
 - c. All exposed metal penetrations and roof accessories shall be finished to match or blend with the roof color.
2. Mechanical penetrations at building facades, including kitchen and dryer vents, bath exhausts and other penetrations shall be aligned horizontally and vertically with other penetrations, window openings and/or other architectural features to present an organized appearance consistent with the architectural character of the building. See *Figure 6.35-1*

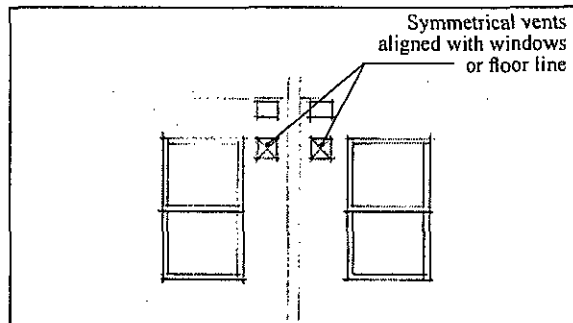

Figure 6.35-1, (Illustrative Only)

6.36 Waste Handling Areas

Applicability

The following guidelines apply at all Development Areas.

General Guidelines

1. All waste handling areas shall either be enclosed in the structure of the building or screened by a wall or fence consistent with architectural character of the building and adequate to prevent view of trash or recycling containers from the street, public access areas, common circulation areas or group open space areas.
2. At dwelling units to be served by individual waste bins, provide a dedicated location for bins, screened as indicated in item 1. above.
3. Adequate lighting shall be provided at the path leading to the waste handling enclosure as well as within the enclosure.
4. Space allocated for recycling shall be consistent with the requirements of Section 17.118 of the Planning Code.

Guidelines for Wood Street Overlay Zone

5. Waste Handling areas are not allowed in the Wood Street or Plaza Overlay Zones unless they conform to the following requirements.
 - a. The waste handling area shall be enclosed entirely within the structure of the building, with access provided by opaque service door.
 - b. The service doors accessing the waste handling shall not face Wood Street or the 16th Street Plaza.

6.40 Exterior Materials

Applicability

The following guidelines apply to all Development Areas except as specified below.

Exceptions

The locations or conditions indicated below are exempt from the guidelines contained in this section:

1. Existing exterior materials on existing buildings

Guidelines.

1. All exterior materials and building components shall be durable and of a high-quality.

2. Exterior Wall Materials

Encouraged: cement plaster (stucco), cement board (panels or planks); wood panels, planks; metal – corrugated panels, flat panels; stone; brick & split face block.

Discouraged: EIFS (Exterior Insulation and Finish Systems), unfinished concrete block, hardboard or plywood siding

Not Allowed: vinyl or aluminum siding

3. Roofing Materials at Sloped Roofs where visible from the street (*roofs of 2:12 slope or greater*)

Encouraged: concrete or clay tile, (s-barrel or flat); high-quality composition shingles; fire-treated wood shakes or shingles; standing seam metal roofing

Discouraged: sheet or roll roofing; synthetic shakes or shingles; high-glaze tiles or glossy painted concrete tiles

4. Roofing Materials at flat roofs (*roofs less than 2:12 slope*)

No limitations

6.41 Exterior Color

Applicability

The following guidelines apply to all Development Areas.

General Guidelines.

1. Each project shall create a cohesive color palette that takes into consideration the finish of all exterior elements.
2. Projects are encouraged to employ more than one body color to articulate the form, rhythm and scale of the building.
3. Accent colors are encouraged where they enhance the architectural character of the development project.

6.42 Exterior Lighting

Applicability

The following guidelines apply to all Development Areas.

Guidelines

1. A minimum average lighting level of one foot candle shall be provided along all designated paths of travel between dwelling units, buildings and site entrances, public streets, and open spaces.
2. Exterior lighting shall be provided immediately adjacent to all entries to the site, buildings, dwelling units and commercial spaces.
3. All exterior light fixtures shall be designed and situated to avoid glare at occupied space.
4. Exterior light fixtures shall be compatible in location, design and finish with the architectural character of the development project.
5. The location and design of exterior lighting adjacent to a street or public access area shall be coordinated with lighting at the adjoining streetscape design.
6. High-pressure and low-pressure sodium lamps are not allowed due to poor color rendition.

6.50 Signage & Graphics

Applicability

The following guidelines apply to all Development Areas.

Coordination with Development Standards

Refer to Section 5:70 of the Development Standards for limitations on the display area and number of signs.

General Guidelines

1. Signs shall respect the architectural elements of the buildings they identify and shall be designed as architectural elements in their own right.
2. Signs shall not obscure architectural elements such as transoms or columns.
3. All exterior signage shall be professionally designed and fabricated of high-quality durable materials.
4. The size of signs and sign letters shall be in scale and proportion to the space in which they are located.
5. The design and alignment of adjacent signs shall be coordinated in order to achieve an organized appearance.
6. The following sign types are not allowed
 - a. Internally lit 'cabinet' signs
 - b. Moving signs
 - c. Blinking or flashing signs
7. Sign lighting shall utilize spotlighting or exposed or halo-lit neon and shall not create glare for pedestrians or motorists.

Guidelines for Projecting Signs

1. Location of projecting signs shall be coordinated to avoid obscuring other signage.

Guidelines for Freestanding Project Signs Serving Residential Uses

1. Free standing signs shall be designed to avoid blocking vehicular or pedestrian site lines.
2. Free standing signs shall not exceed five (5) feet in height.

6.60 Planting Areas

Applicability

The following guidelines apply to all Development Areas.

Coordination with Development Standards

Refer to Section 5.61 of the Development Standards for standards related to provision of trees at surface parking areas

General Guidelines

1. Planting areas should be designed to be attractive year round through provision of a variety of textures and seasonal color.
2. Planting shall be utilized for the following purposes:
 - a. to emphasize and enhance pedestrian and vehicular entries.
 - b. to screen service areas
 - c. to provide buffering between non-compatible site uses.
 - d. to provide buffering between private and group usable outdoor space
 - e. to improve appearance and usability of outdoor space.
3. Planting shall take into consideration public safety, and shall not interfere with the site lines or movement for motorists, pedestrians, or bicyclists.

Guidelines for Planting at Street Frontage

1. Setback areas between the back of sidewalk and the building line shall be designed to provide the maximum amount of planted area. A minimum of 75% of the required setback areas shall be planted.
2. Planting in required street setbacks shall be designed to not exceed 36" in height to maintain sight lines for pedestrian and residents except for trees limbed to provide visibility through and below the canopy. Higher planting are acceptable adjacent to buildings to provide privacy at street facing windows.
3. Trees shall be limbed to provide visibility through and below the canopy.
4. Where no street setback is required, planting areas are encouraged between the building face and the back of sidewalk to soften and enhance the street frontage.

Pot Sizes

1. Soil depth in pots should not be less than 18 inches.

Selection of Plant Materials

1. Trees, shrubs and ground covers should be selected primarily from drought tolerant native or Mediterranean species.
2. Selection of plant materials should take into account solar orientation, building shadow and soil characteristics to ensure sustained growth.
3. Trees should be a mix of deciduous and evergreen, and should be selected on the basis of hardiness and ease of maintenance.
4. Plant sizes should meet the following minimum sizes at the time of planting
 - a. Deciduous Shade Trees: 2 inch caliper
 - b. Ornamental trees: 1.5 inch caliper
 - c. Evergreen trees: 2 inch caliper
 - d. Multi-stem ornamental trees: 6-8 feet in height
 - e. Shrubs: 5 gallon container
 - f. Vines: 1 gallon container
 - g. Ground cover and perennials: 2-1/4 inch pots

Irrigation

1. All planting areas should be provided with an automatic irrigation system that meets the following criteria
 - a. Utilization of bubblers, drip systems, and other water efficient strategies
 - b. Provision of sufficient coverage to all landscape areas
 - c. Minimum overspray on non-planted areas.
 - d. Easily maintained.

Maintenance of Planted Areas

1. All landscape areas shall be maintained in conformance with standards set forth in Section 17.124.020 of the Planning Code.